



## **Make your own accessory**

### Getting started with modular fashion

Nuria Robles | Fab Lab León | July 2021



This project has received funding from the European Union's Horizon 2020 research and innovation programme under grant agreement No 101006203.

# Modular garment:

Digital Design +  
Lasercutter

Assembly the modules to  
make an accessory



Zoe Romano | Fabricademy



# Modular fashion

Zero waste

Modular  
fashion

Tessellation

Interlocking

**How to create clothes and accessories with 2D vectorial designs**

Interlocking these pieces we will obtain 3D seamless geometries



# What will we learn today?

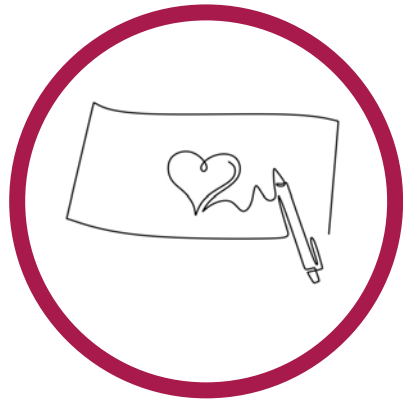

We will design a module with interlocks using **pens and paper**

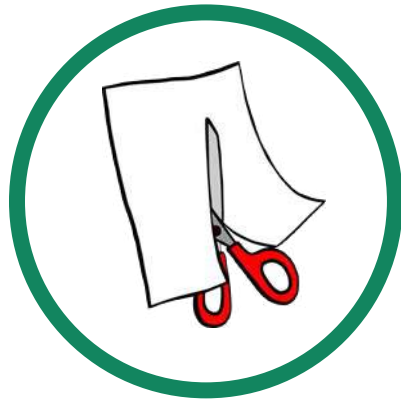

We will cut the modules with the **scissors** and test the connections between modules



We will design digitally a module in **inkscape**



We will cut some felt modules in the **laser cutter**

# Lab equipment

How to use the Lab equipment to make seamless clothes

## Machines / Tools

- Laser cutter
- Cutter / Scissors
- Ruler ...

## Software

- Fusion 360
- **Inkscape**
- Rhinoceros

## Materials

- Paper/ Cardboard
- **Felt**
- Leather
- Neoprene...



# Workflow



## Design in paper

Sketch, design a module with interlocks on paper



## Cut with scissors

Cut 3 or 4 pieces on paper

## Assemble

Assemble the pieces to test the connections



## Digital Design

Design the modules on inkscape



## Laser cutting

Lasercut the digital modules

## Final Assembling

Connect the modules to make a garment / accessory



# Design in paper

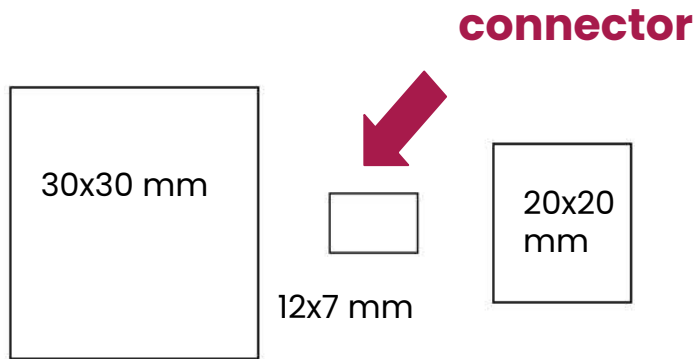

Make a simple module:

- Draw a 30x30 mm square
- Draw a 20x20 mm square
- Draw a 12x7 mm rectangle (connector)



# Design in paper

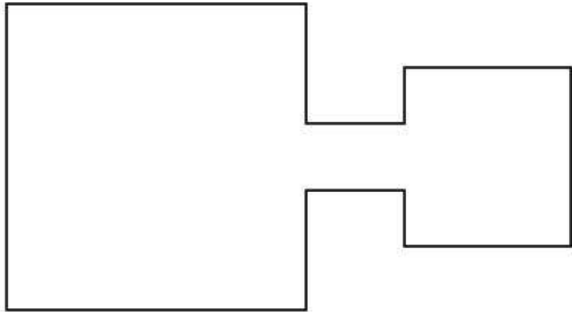
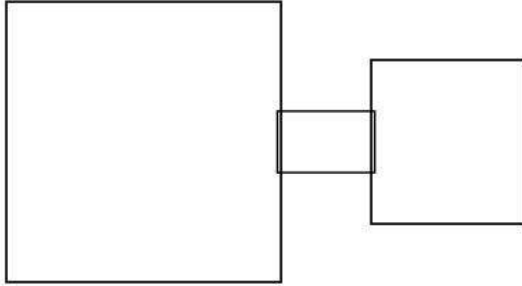

- Align all the pieces
- Draw the external shape of the group of the pieces





# Make the connections

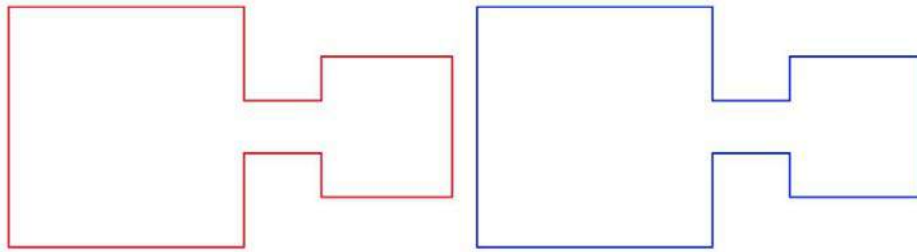

- Replicate 2 equal pieces

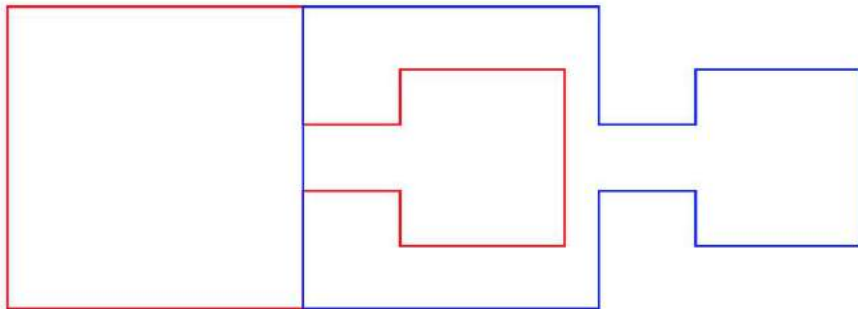

- Overlap them



# Make the connections

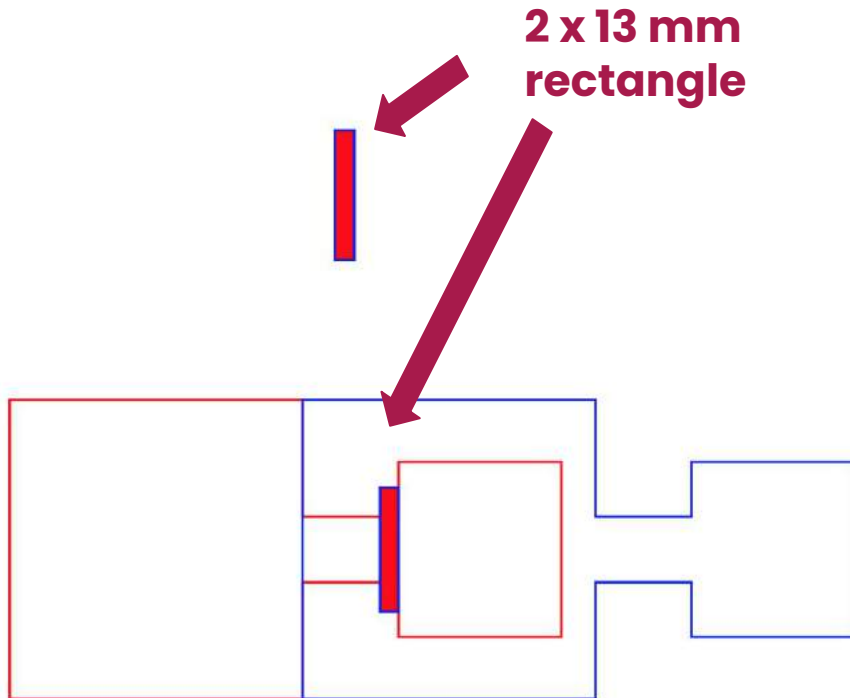

Draw a 2x13mm rectangle for the interlocking near the smaller square

Note: 2mm is the thickness of the material (felt)



# Cut the final shape

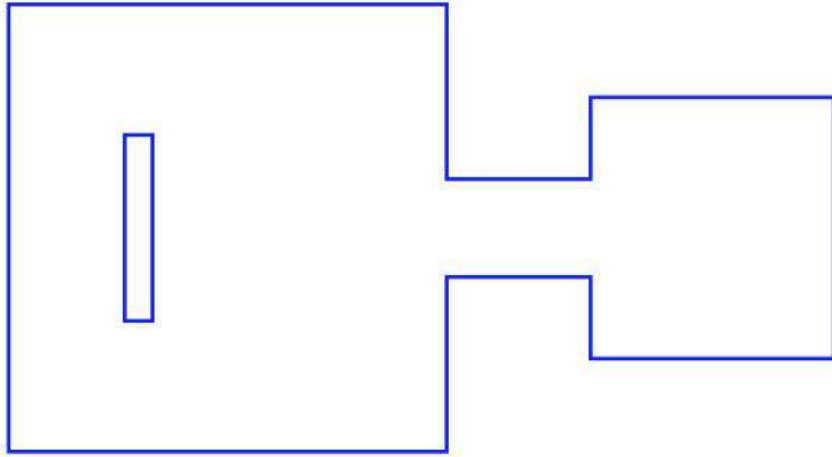

Draw a 2x13mm  
rectangle for the  
interlocking near the  
smaller square

Cut it with the scissors



# Assemble

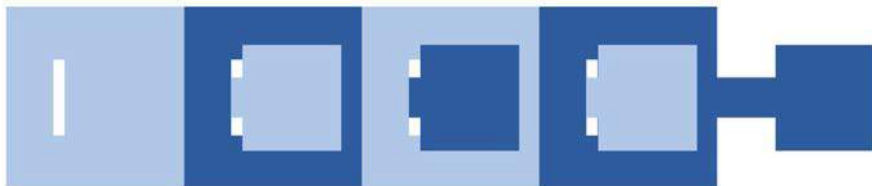
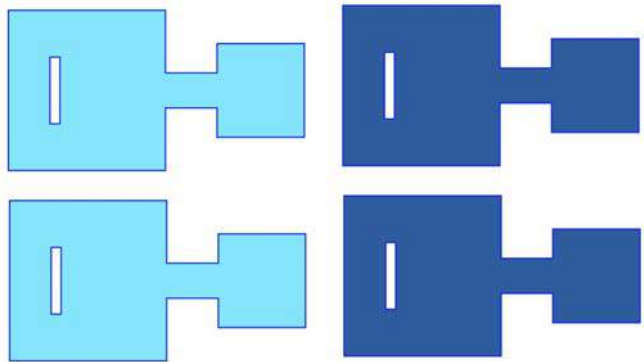

Draw 4 modules, cut them with the scissors and connect them

Think about an accessory that you can make with the group of modules

Try to combine different colors



# Digital Design: Inkscape tutorial: [File](#)

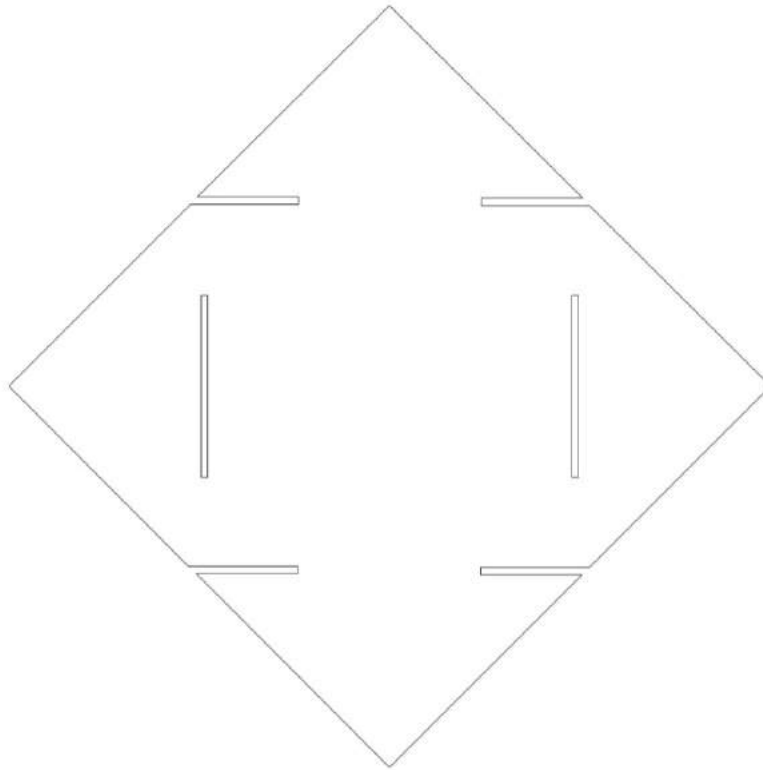



# Inkscape tutorial: 1-Open-Inkscape

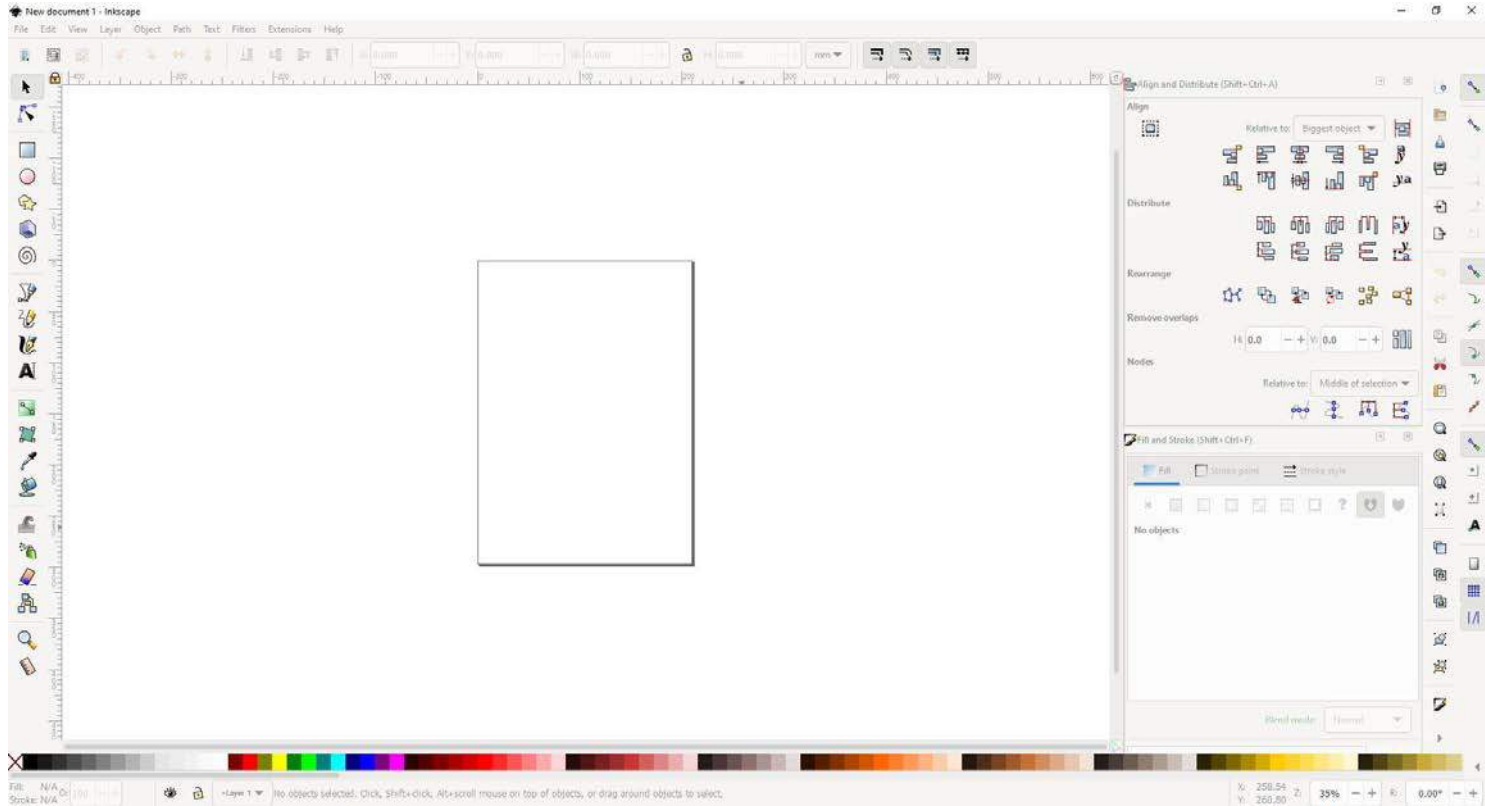



# Inkscape tutorial: 2-Create-square

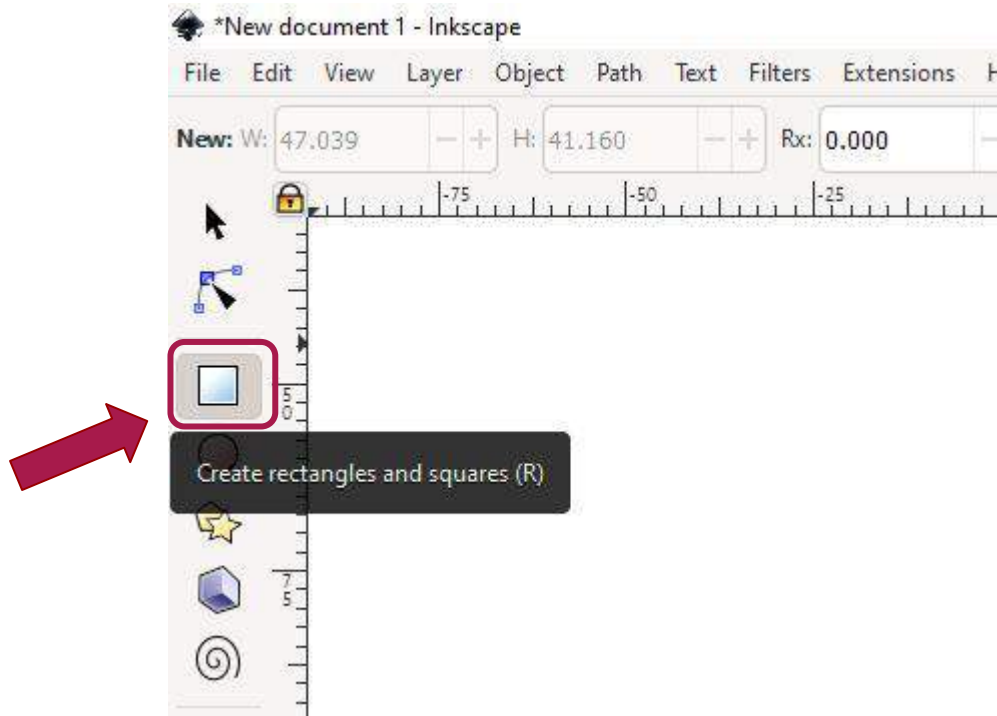



# Inkscape tutorial: 3-Size-square

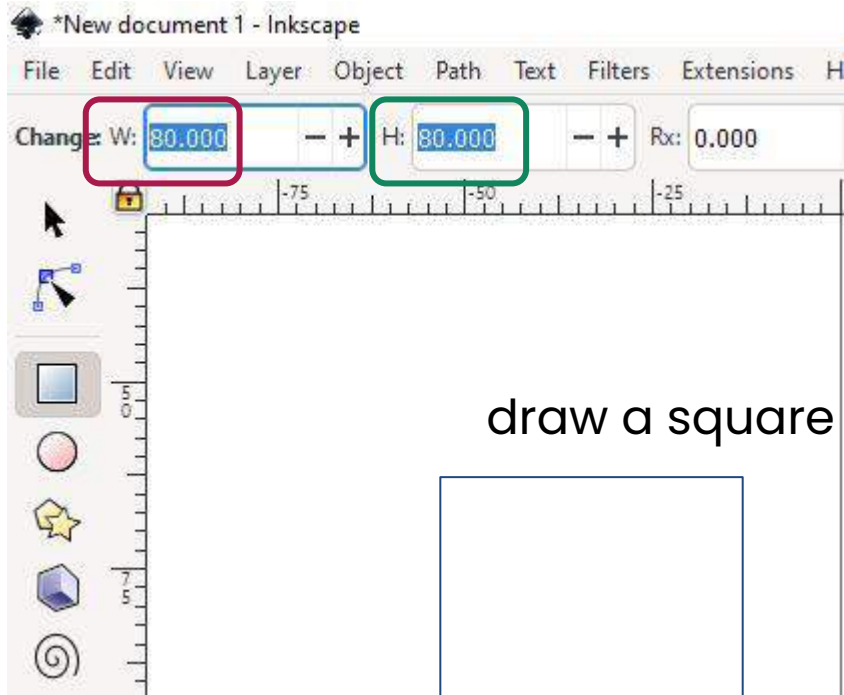

draw a square **80mm Width** and **80 mm Height**





# Inkscape tutorial: 4-Object-Transform-Rotate

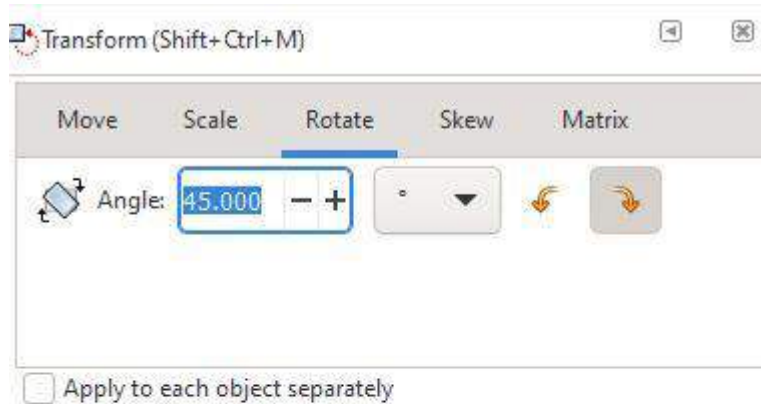

Object > Transform > Rotate





# Inkscape tutorial: 4-Before-Rotate-Add-square-color

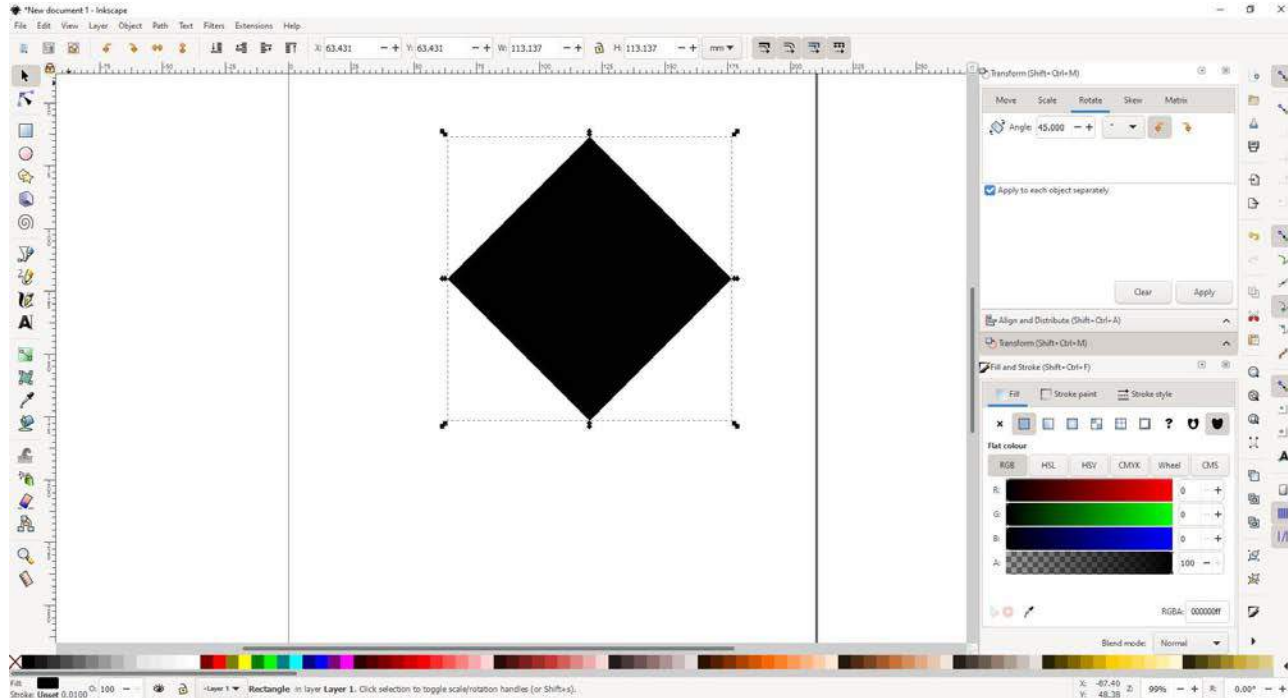

Object > Fill and stroke  
**Fill: No fill**



# Inkscape tutorial: 4-Before-Rotate-Add-square-stroke

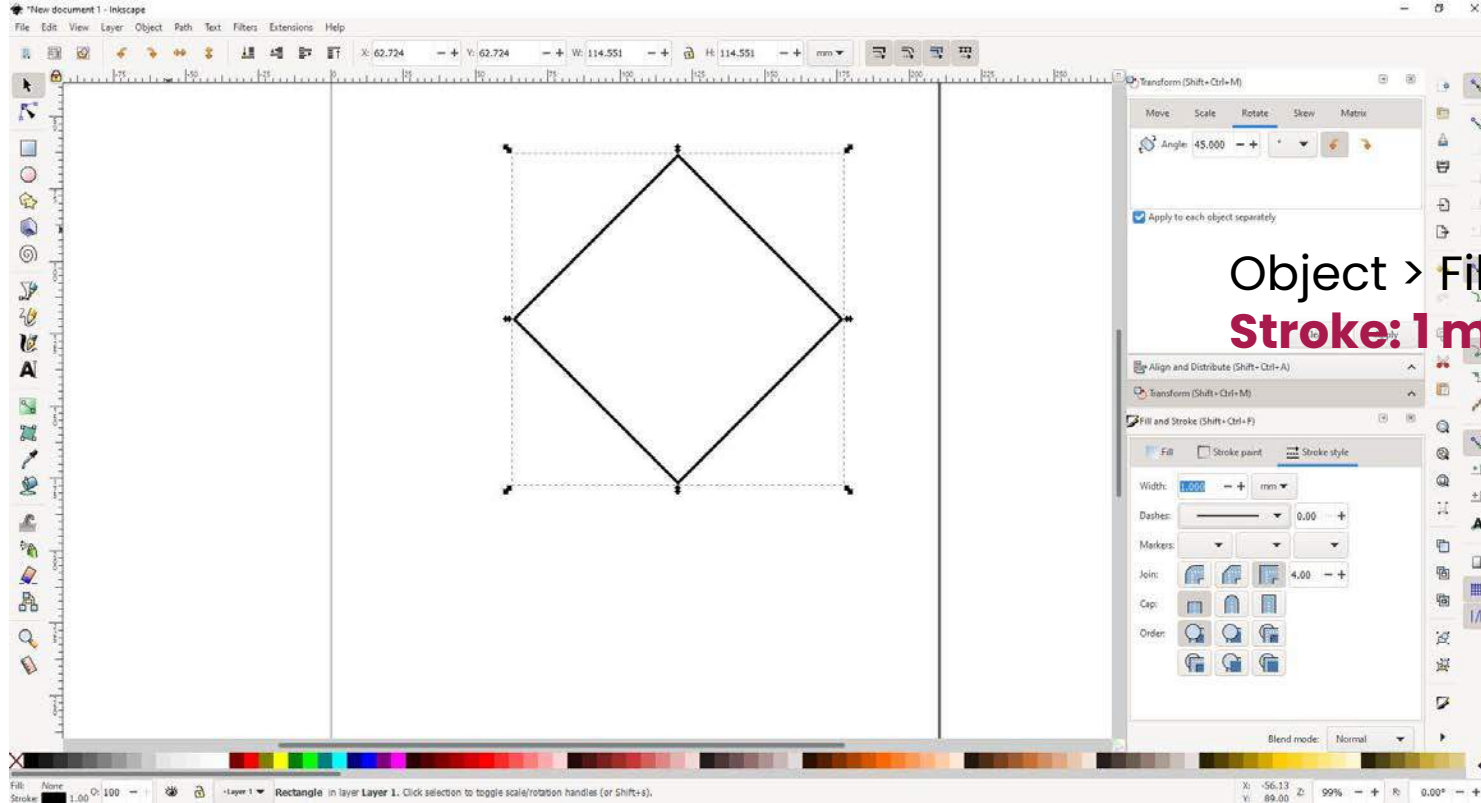

Object > Fill and stroke  
**Stroke: 1 mm**



# Inkscape tutorial: Create a 2nd square inside (middle point)

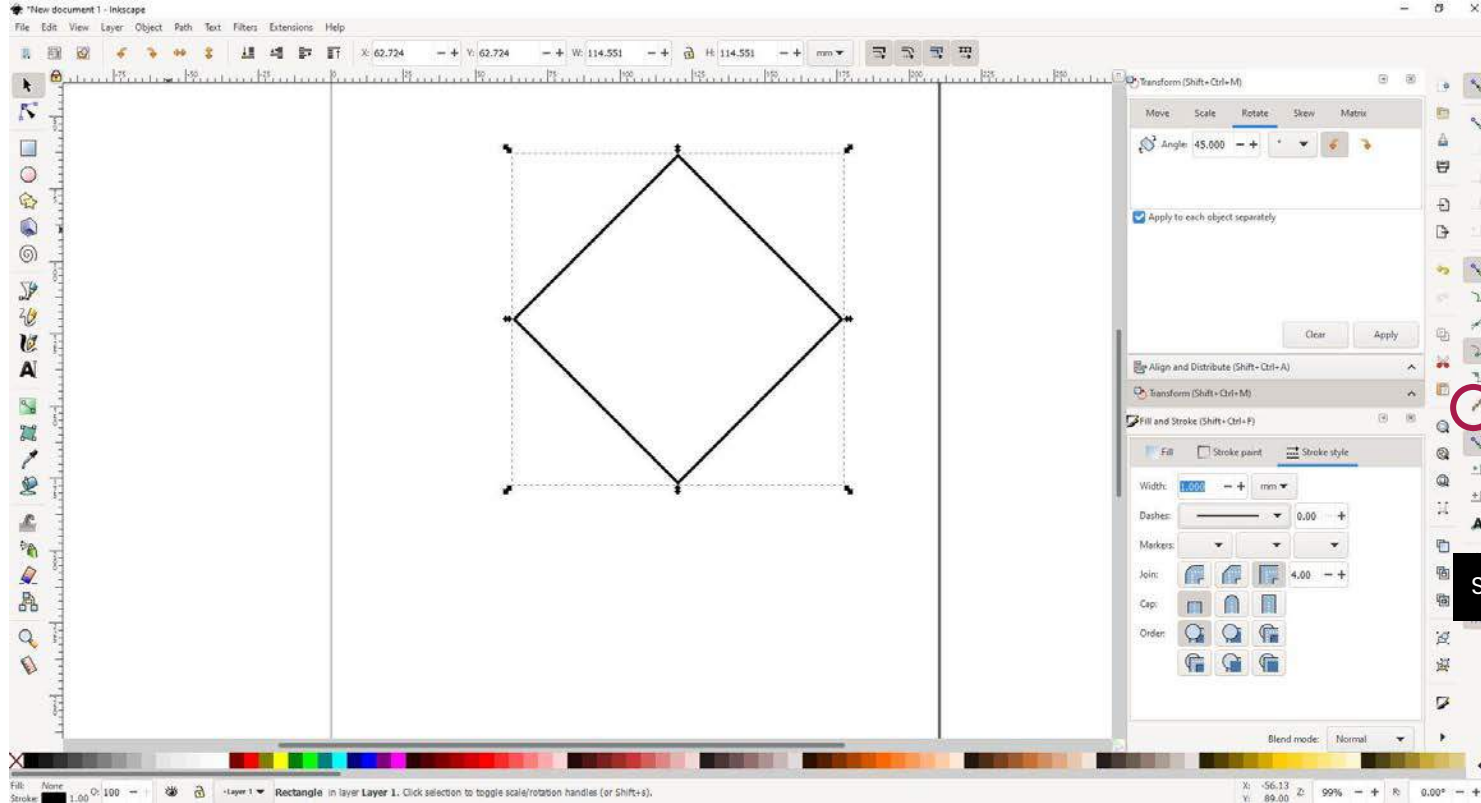

Snap midpoints of line segments



# Inkscape tutorial: Create a 2nd square inside (middle point)



Snap midpoints of line segments

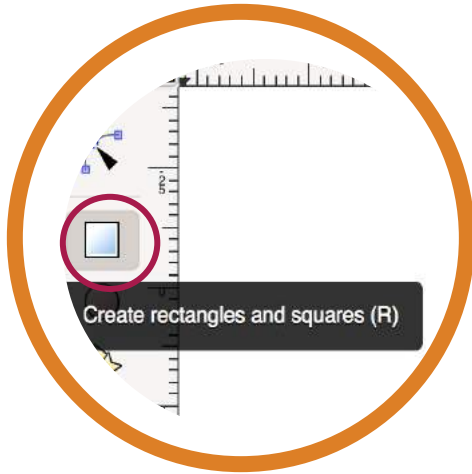

1-Draw a square with the snap midpoints selected

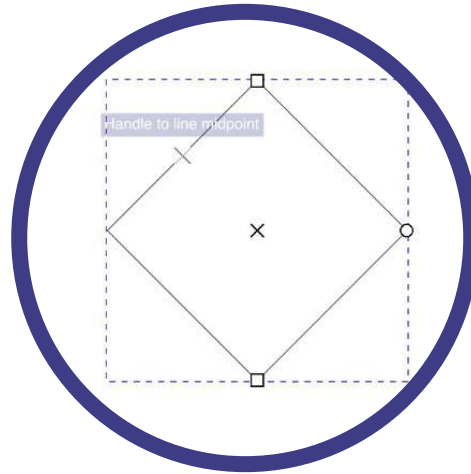

2-First corner of the square in the middle of on of the square lines

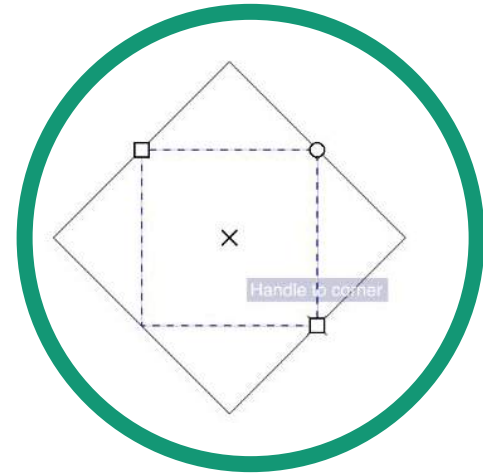

3-Drag the square to the midpoint of the opposite square line.



# Inkscape tutorial: 5-Create-2nd-square-inside

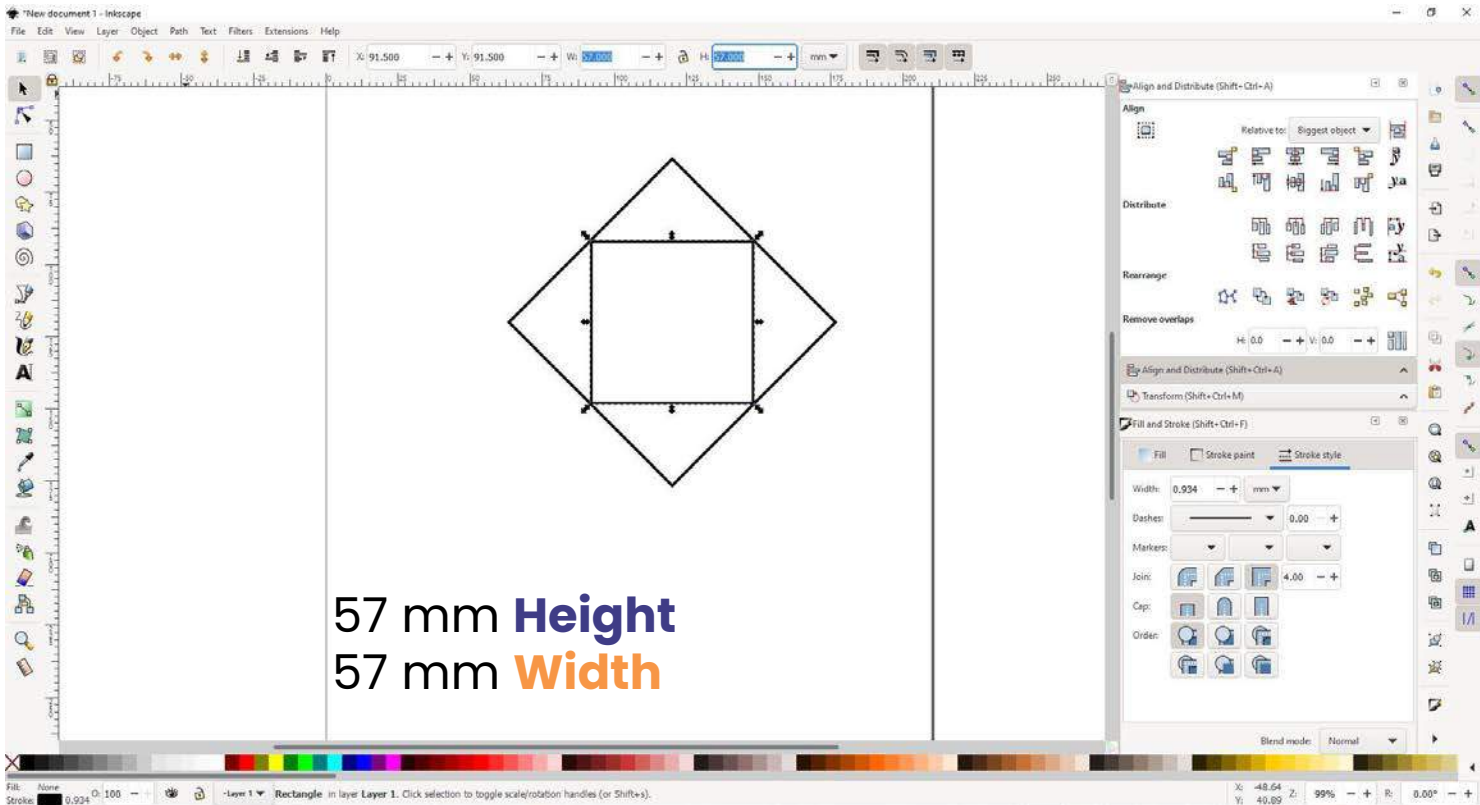



# Inkscape tutorial:

## 6-Create-rectangle-half2nd-squaresize-x-materialthic kness

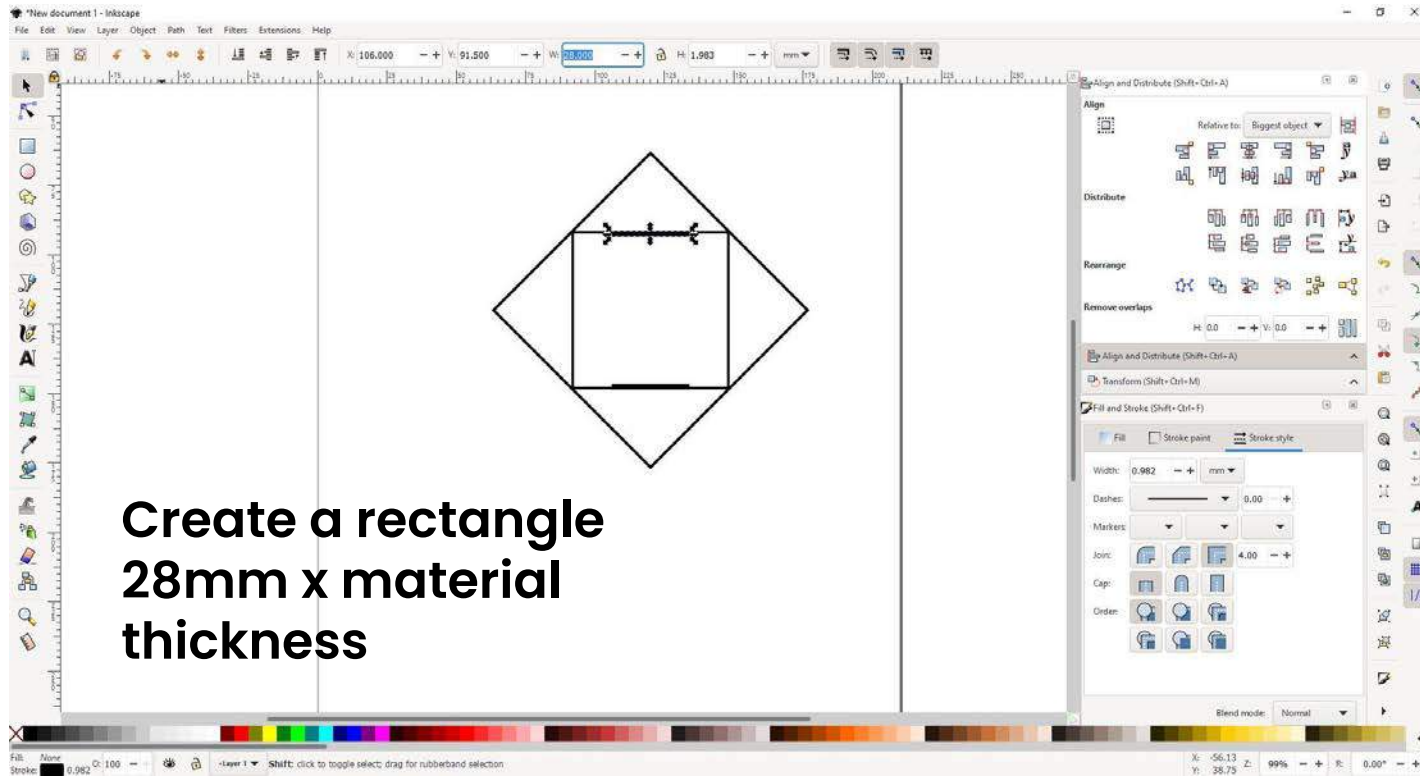



# Inkscape tutorial: 7-Copy-and-center-on-each-side

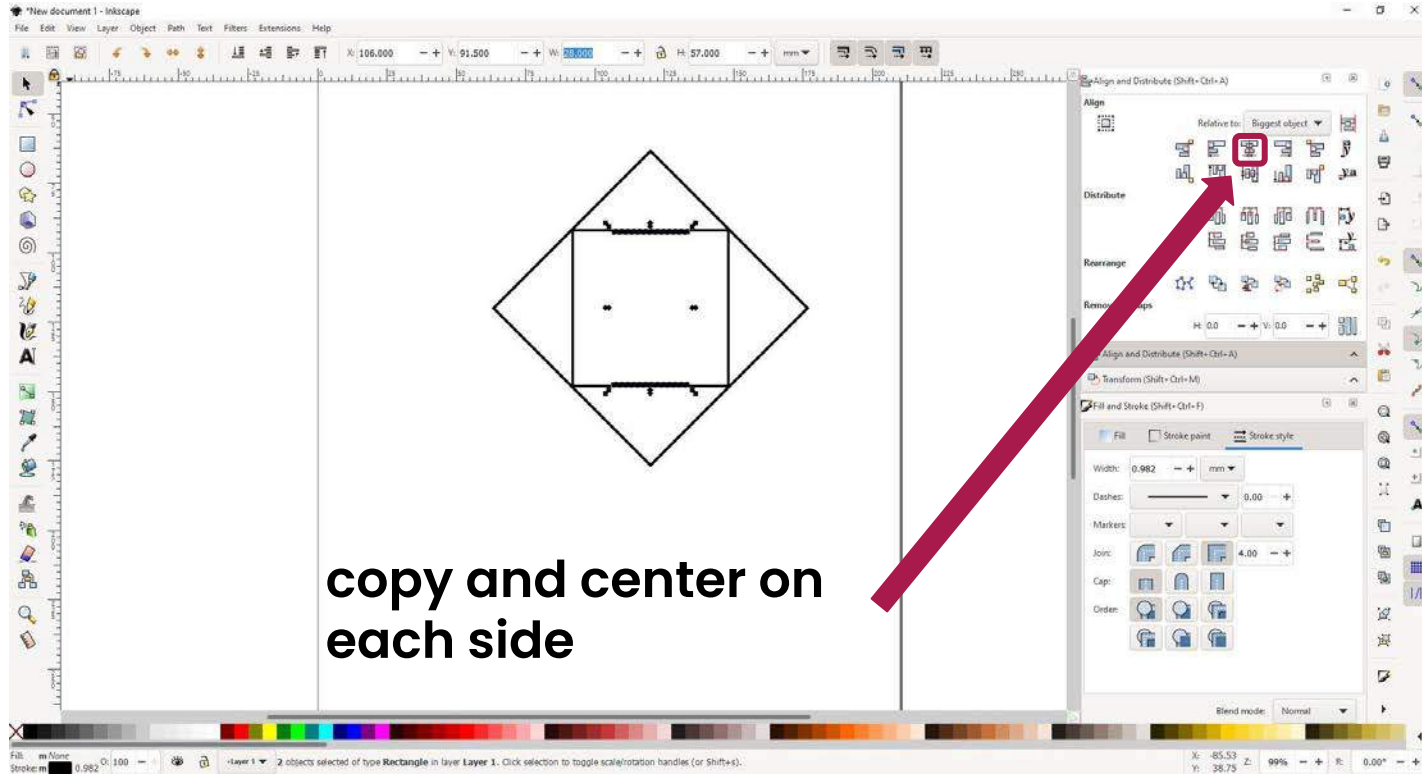





# Inkscape tutorial: 8-Create-rectangle-externalpart

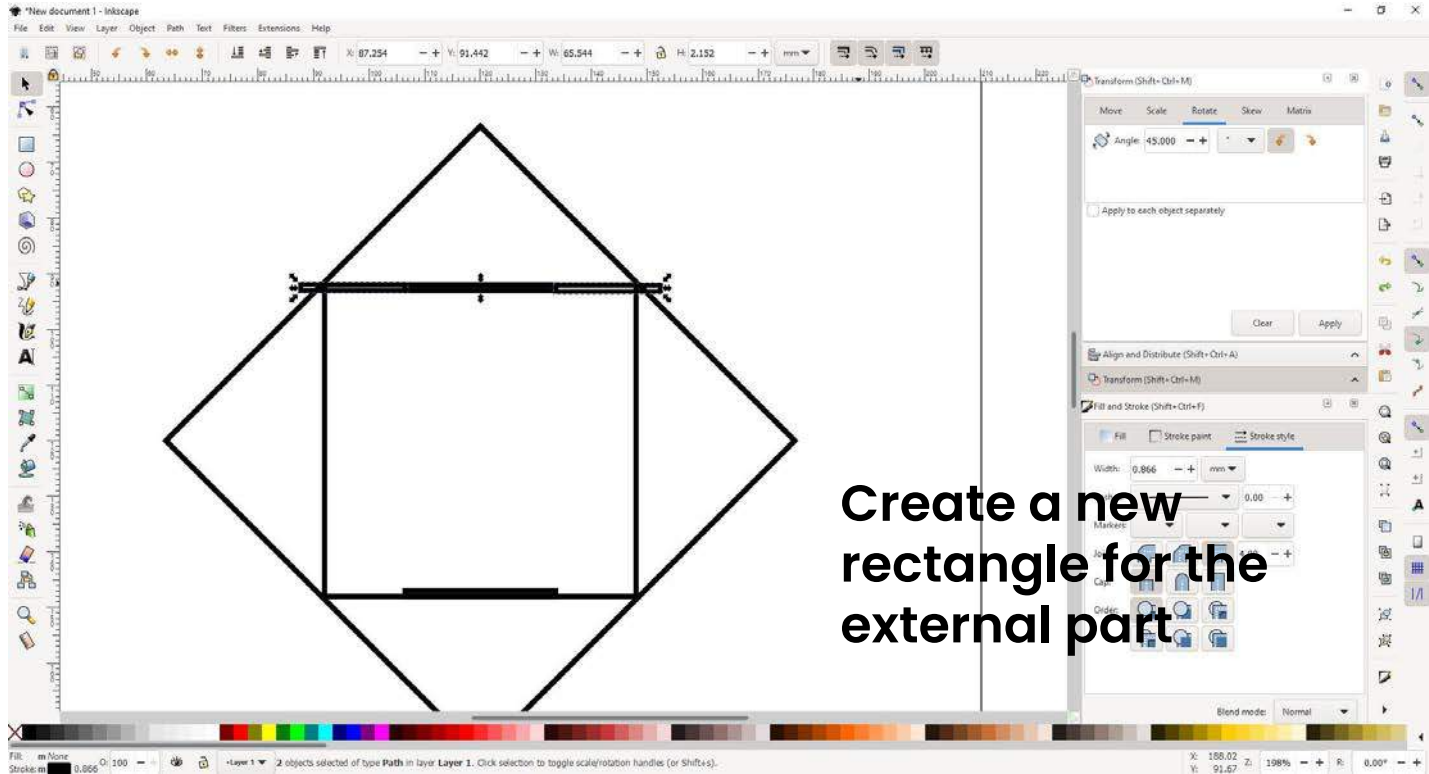



# Inkscape tutorial: 9-duplicate-Create-rectangle-externalpart

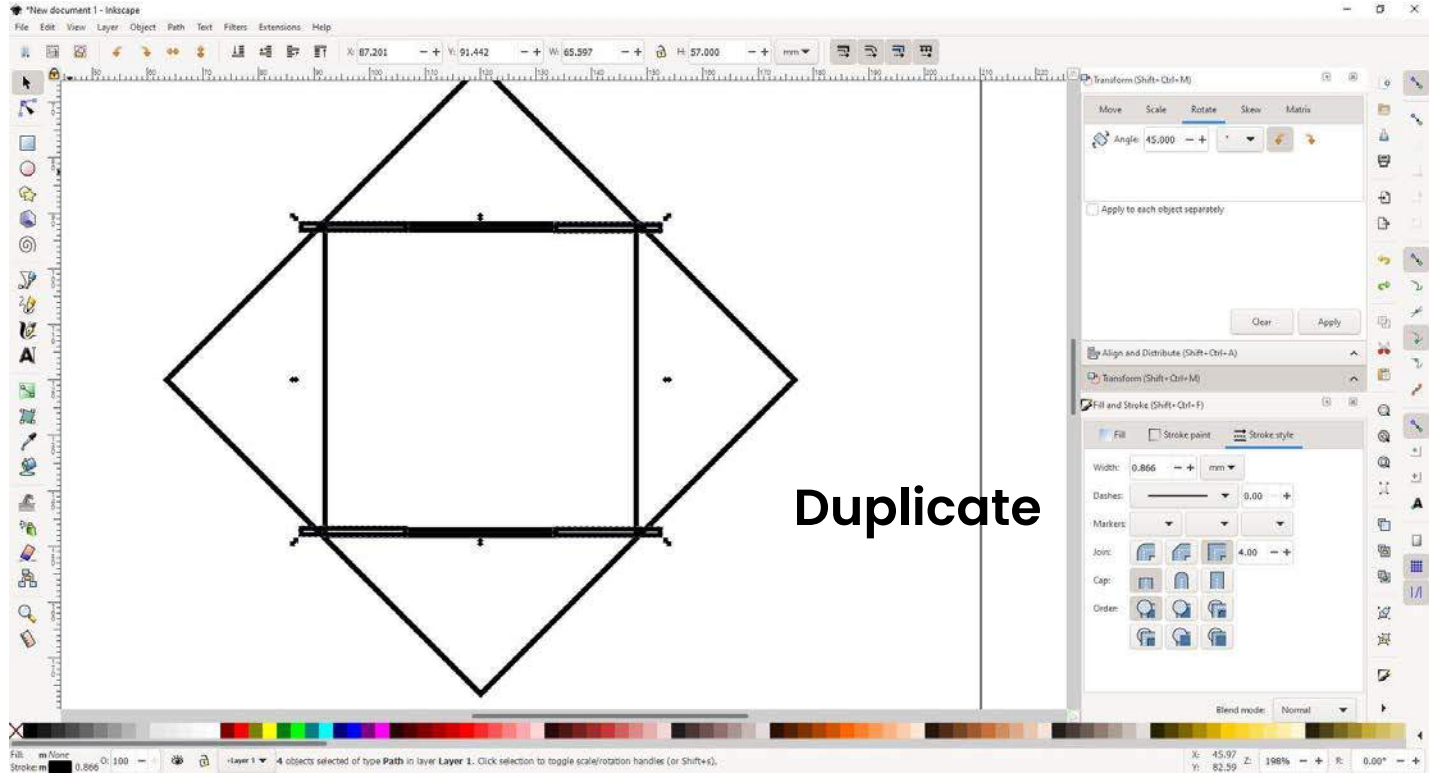



# Inkscape tutorial: 10-rotate-internal-square-90deg

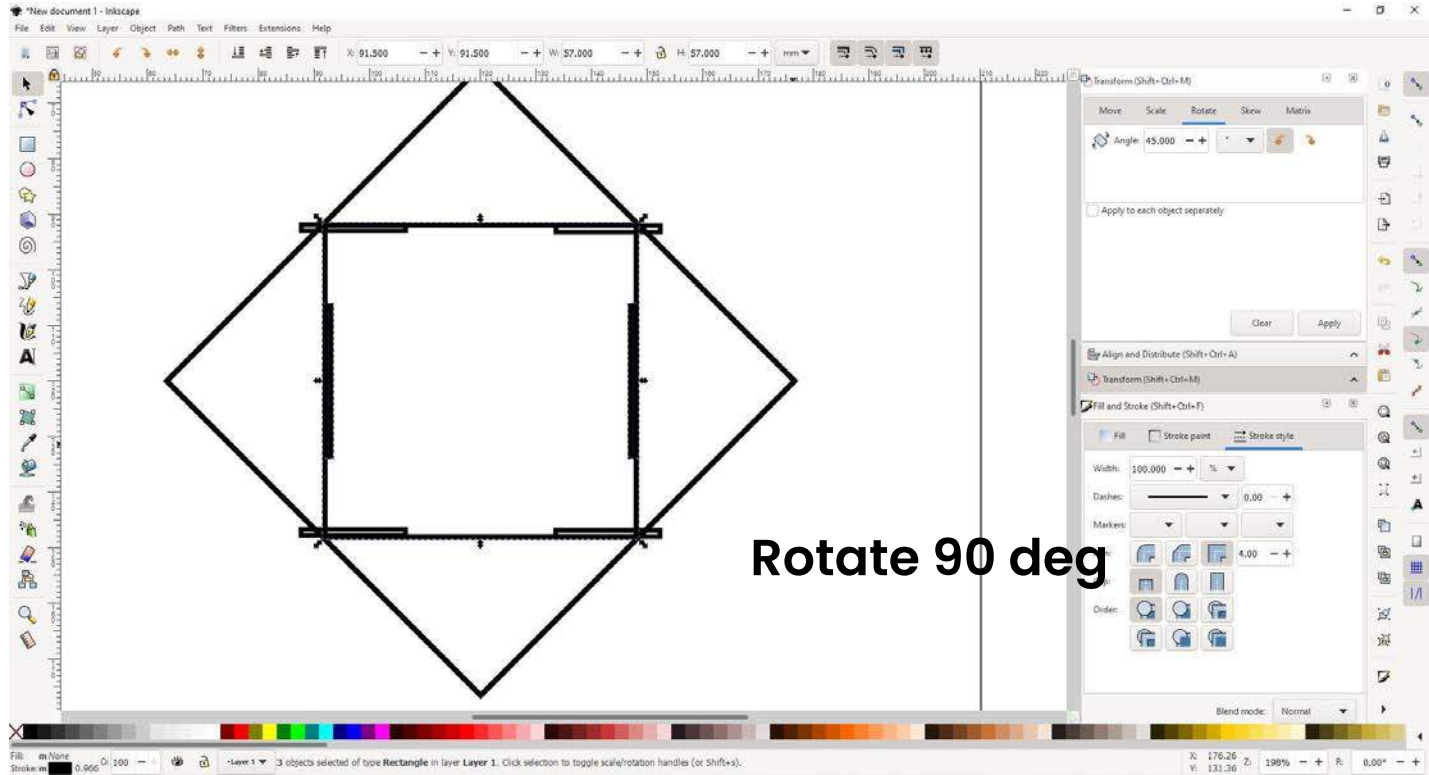



# Inkscape tutorial: 11-suppr-internalsquare

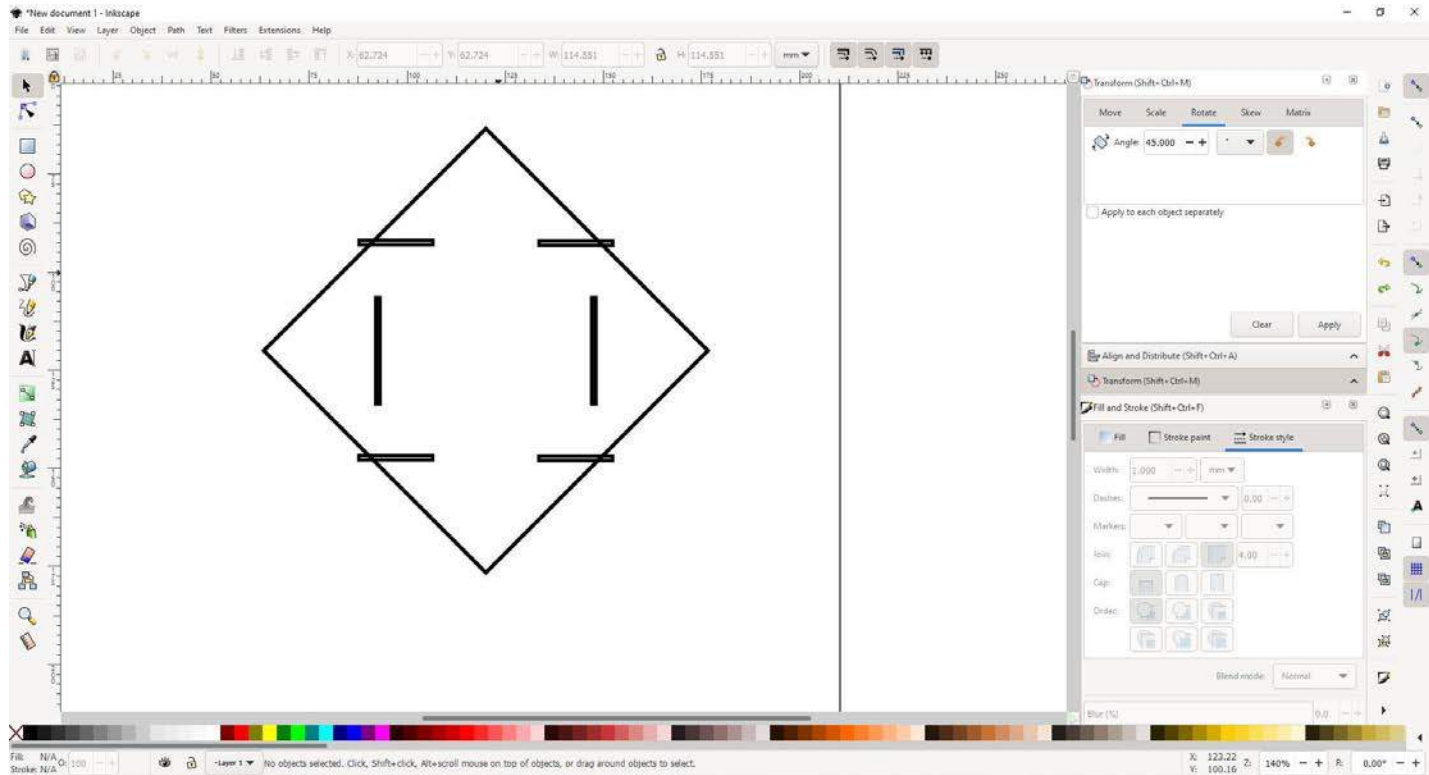



# Inkscape tutorial: 12-path-difference-

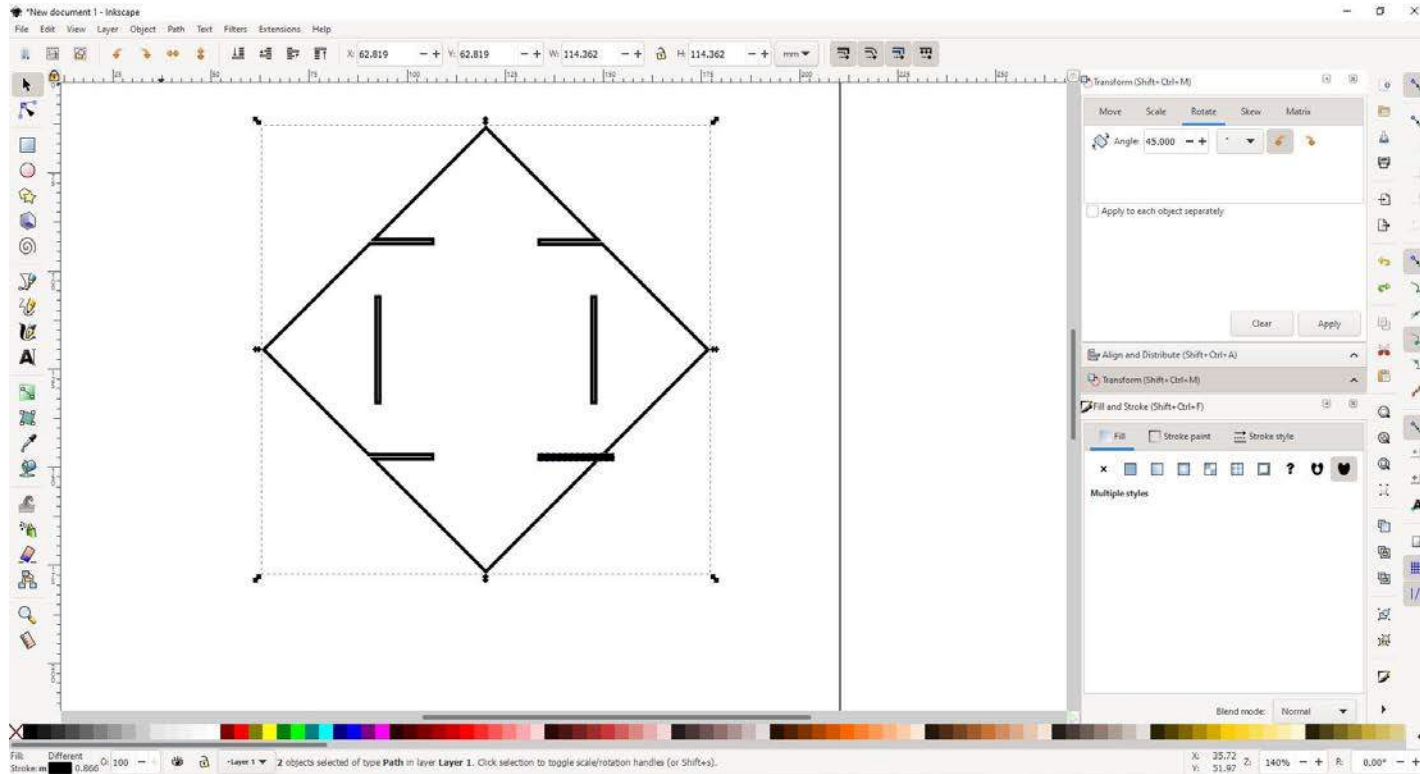



# Inkscape tutorial: 13-select-all-strokesize-forlasercut

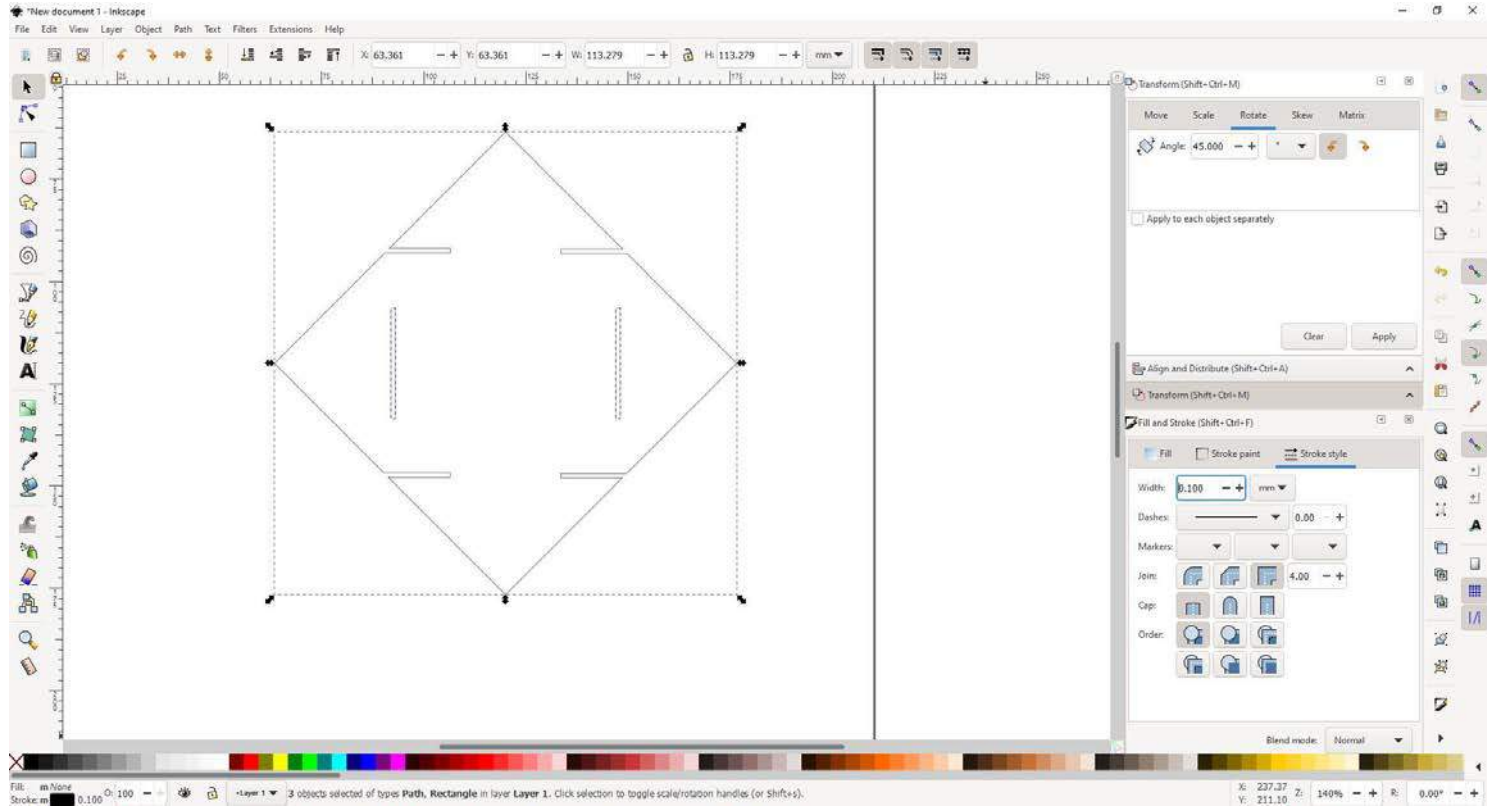



# Inkscape tutorial: save as PDF to cut in the lasercutter

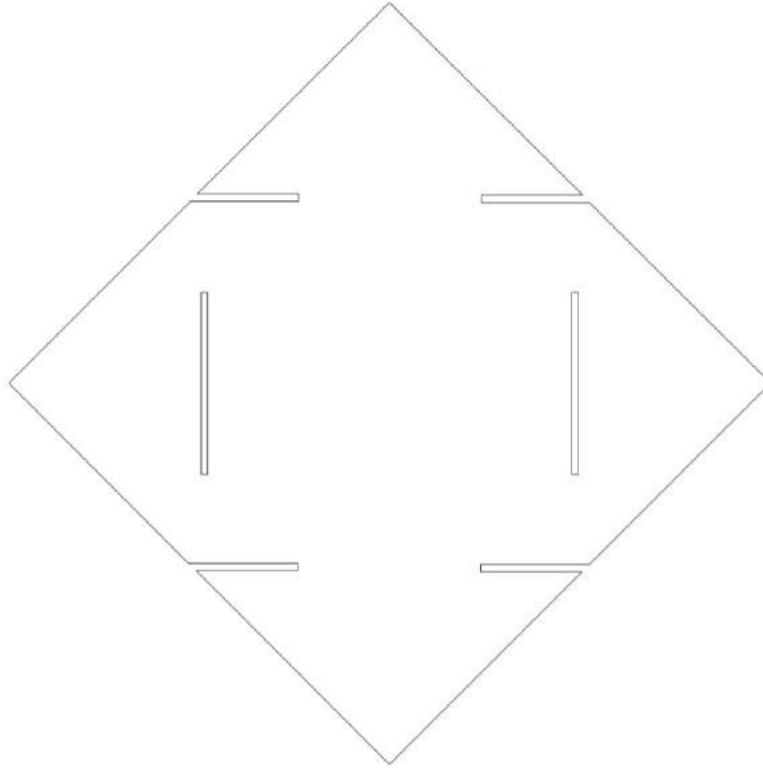



# LaserCut and Interlock the modules







**Next step**

**Challenge :**

**Try to design the Takehiro  
Ando Cuma piece**

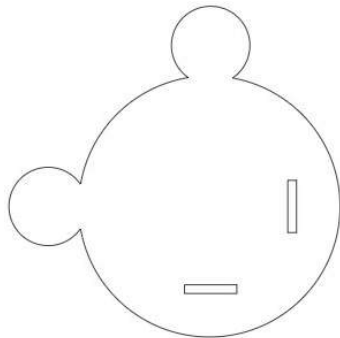



**Next step**

**Share your creations :**

**We love to see different models,  
please , share yours in IG and tag  
**@shemakes\_eu @fabricademy**  
**@fablableon and @you****



**Next step**

**Challenge 2:**

**Make a garment**



# Design the garment

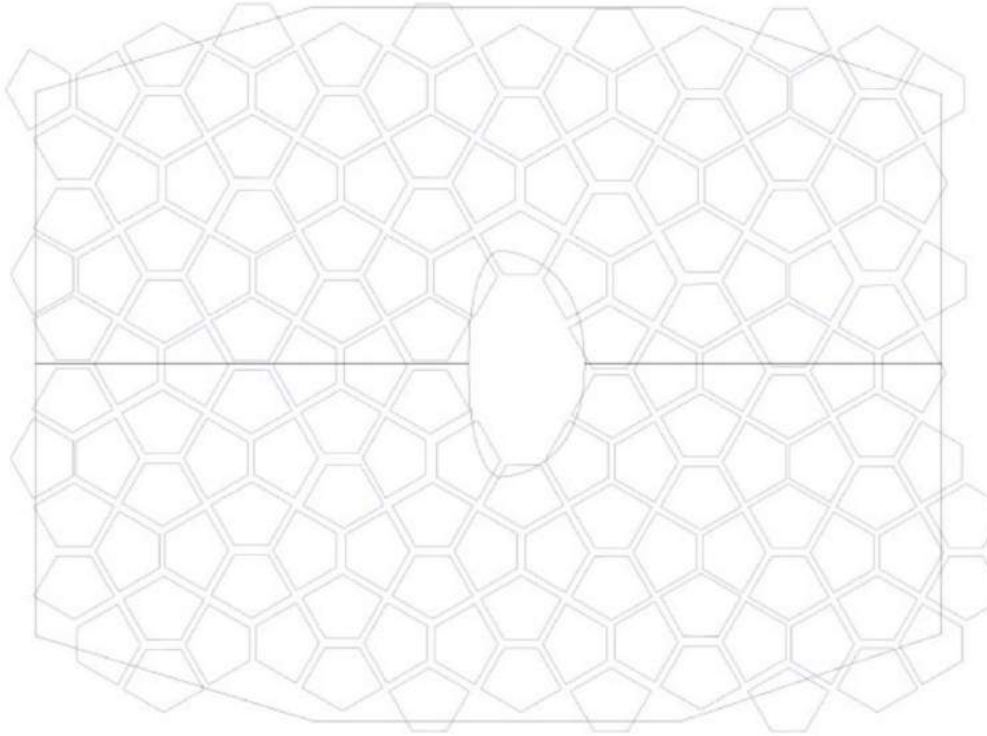

- Design a module in inkscape with the interlockings
- Use one of the flat sewing patterns to have an idea of the number of pieces you need



# Examples

---

## Galya Rosenfeld



Zoe Romano | Fabricademy



# Examples

## Mary Ann Williams



Zoe Romano | Fabricademy



oscircularfashion.com



05/11/2018  
by Fanni Huszár 1 12



02/11/2018  
by Fanni Huszár 0 14



03/05/2018  
by Wei Cheung 0 3



01/05/2018  
by Sofia Guridi 0 2



24/10/2018  
by Dotun Ajewole 0 16

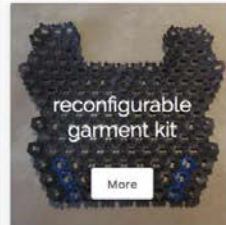

reconfigurable  
garment kit  
More  
23/10/2018  
by Romain Di Vozzo 1 10



23/10/2018  
by Chiara Ganzerla 0 0



21/10/2018  
by teresa van twuijver 1 10



26/04/2018  
by esin durmaz 0 4



19/04/2018  
by Luis Dulanto 0 12

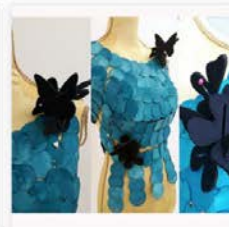

02/03/2018 0 0



02/03/2018 0 0

# shemakes

## Thank you

[www.shemakes.eu](http://www.shemakes.eu)



This project has received funding from the European Union's Horizon 2020 research and innovation programme under grant agreement No 101006203.