



Make your own garment

Getting started with modular fashion

Nuria Robles | Fab Lab León | July 2021



This project has received funding from the European Union's Horizon 2020 research and innovation programme under grant agreement No 101006203.

Modular garment:

Digital Design +
Laser cutter

Assembly the modules to
make an accessory



Zoe Romano | Fabricademy



Modular fashion

Zero waste

Modular
fashion

Tessellation

Interlocking

How to create clothes and accessories with 2D vectorial designs

Interlocking these pieces we will obtain 3D seamless geometries



What will we learn today?

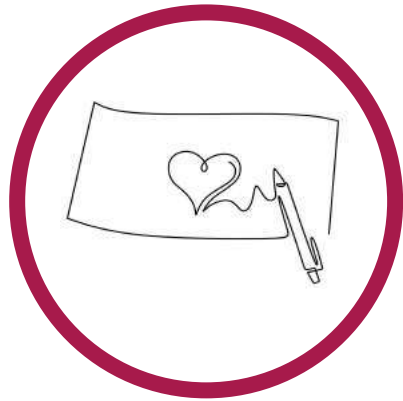

We will design a module with interlocks using **pens and paper**

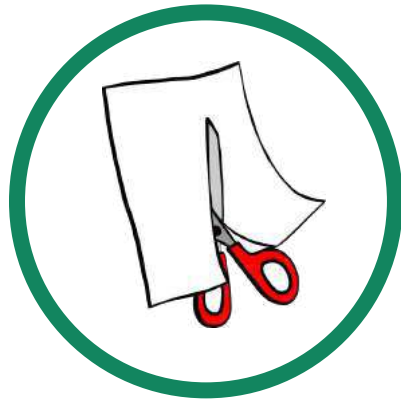

We will cut the modules with the **scissors** and test the connections between modules



We will design digitally a module in **inkscape**



We will cut some felt modules in the **laser cutter**

Lab equipment

How to use the Lab equipment to make seamless clothes

Machines / Tools

- Laser cutter
- Cutter / Scissors
- Ruler ...

Software

- Fusion 360
- **Inkscape**
- Rhinoceros

Materials

- Paper/ Cardboard
- **Felt**
- Leather
- Neoprene...



Workflow



Design in paper

Sketch, design a module with interlocks on paper



Cut with scissors

Cut 3 or 4 pieces on paper

Assemble

Assemble the pieces to test the connections



Digital Design

Design the modules on inkscape



Laser cutting

Lasercut the digital modules

Final Assembling

Connect the modules to make a garment / accessory



Design in paper

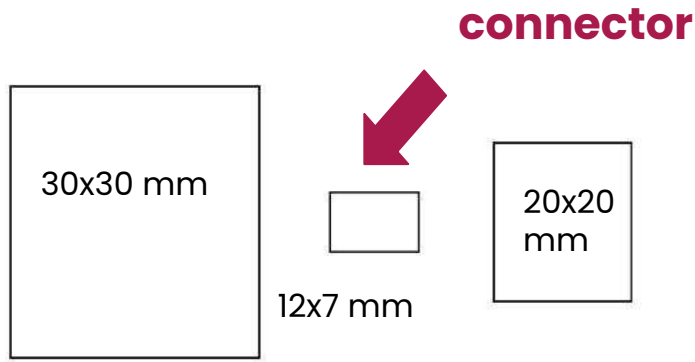

Make a simple module:

- Draw a 30x30 mm square
- Draw a 20x20 mm square
- Draw a 12x7 mm rectangle (connector)



Design in paper

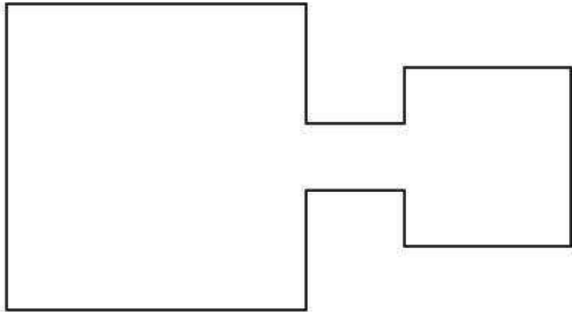
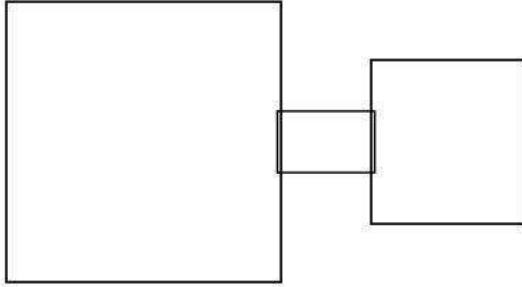

- Align all the pieces
- Draw the external shape of the group of the pieces



Make the connections

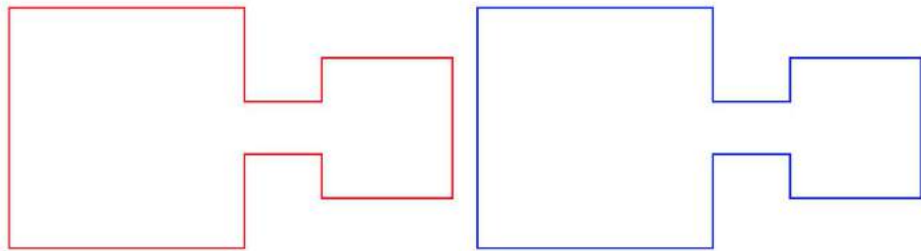

- Replicate 2 equal pieces

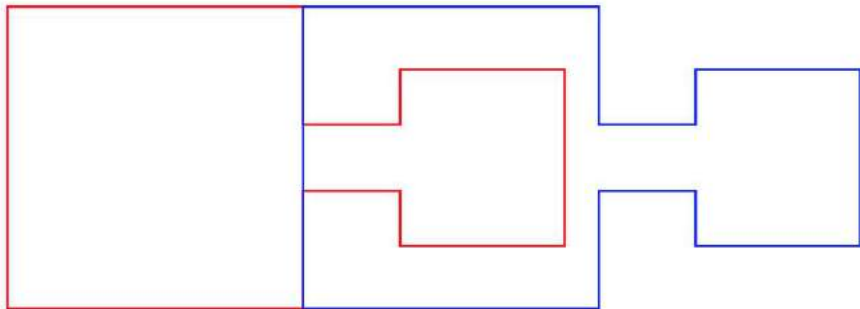

- Overlap them



Make the connections

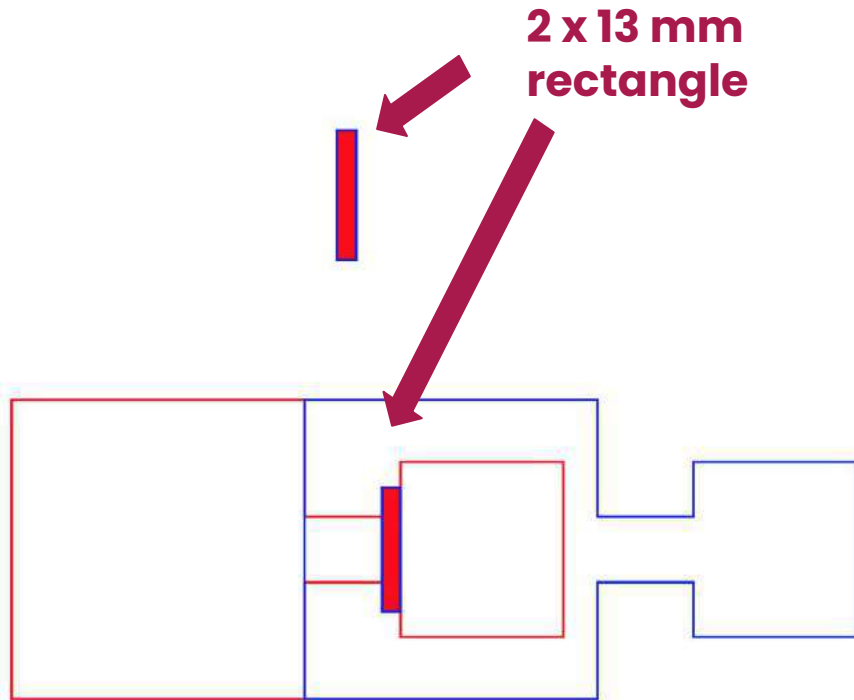

Draw a 2x13mm rectangle for the interlocking near the smaller square

Note: 2mm is the thickness of the material (felt)



Cut the final shape

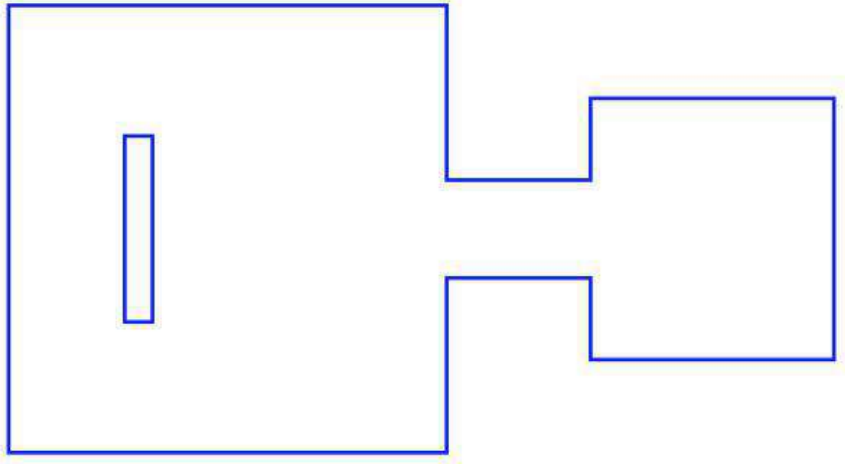

Draw a 2x13mm
rectangle for the
interlocking near the
smaller square

Cut it with the scissors



Assemble

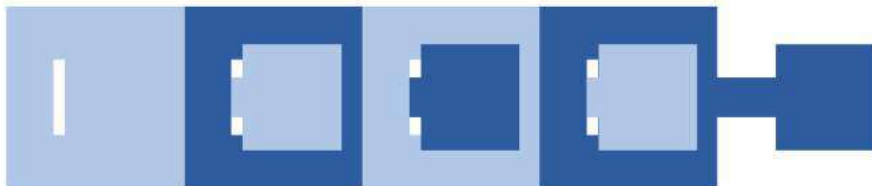
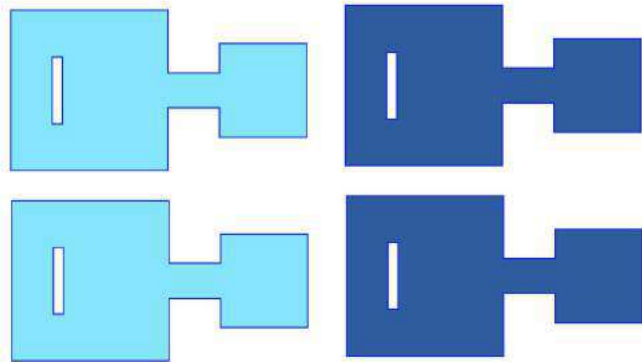

Draw 4 modules, cut them with the scissors and connect them

Think about an accessory that you can make with the group of modules

Try to combine different colors



Digital Design: Inkscape tutorial: [File](#)

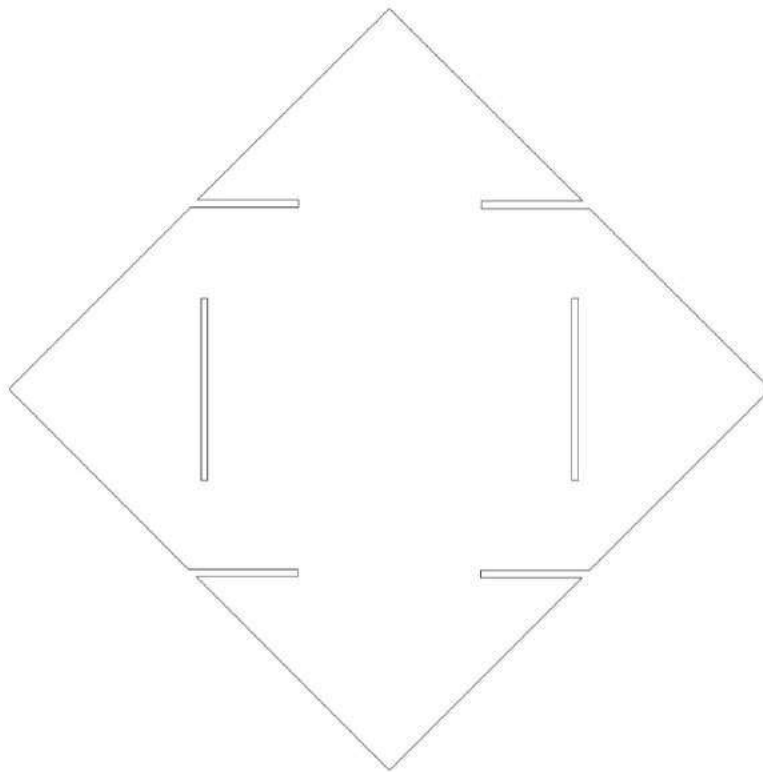



Inkscape tutorial: 1-Open-Inkscape

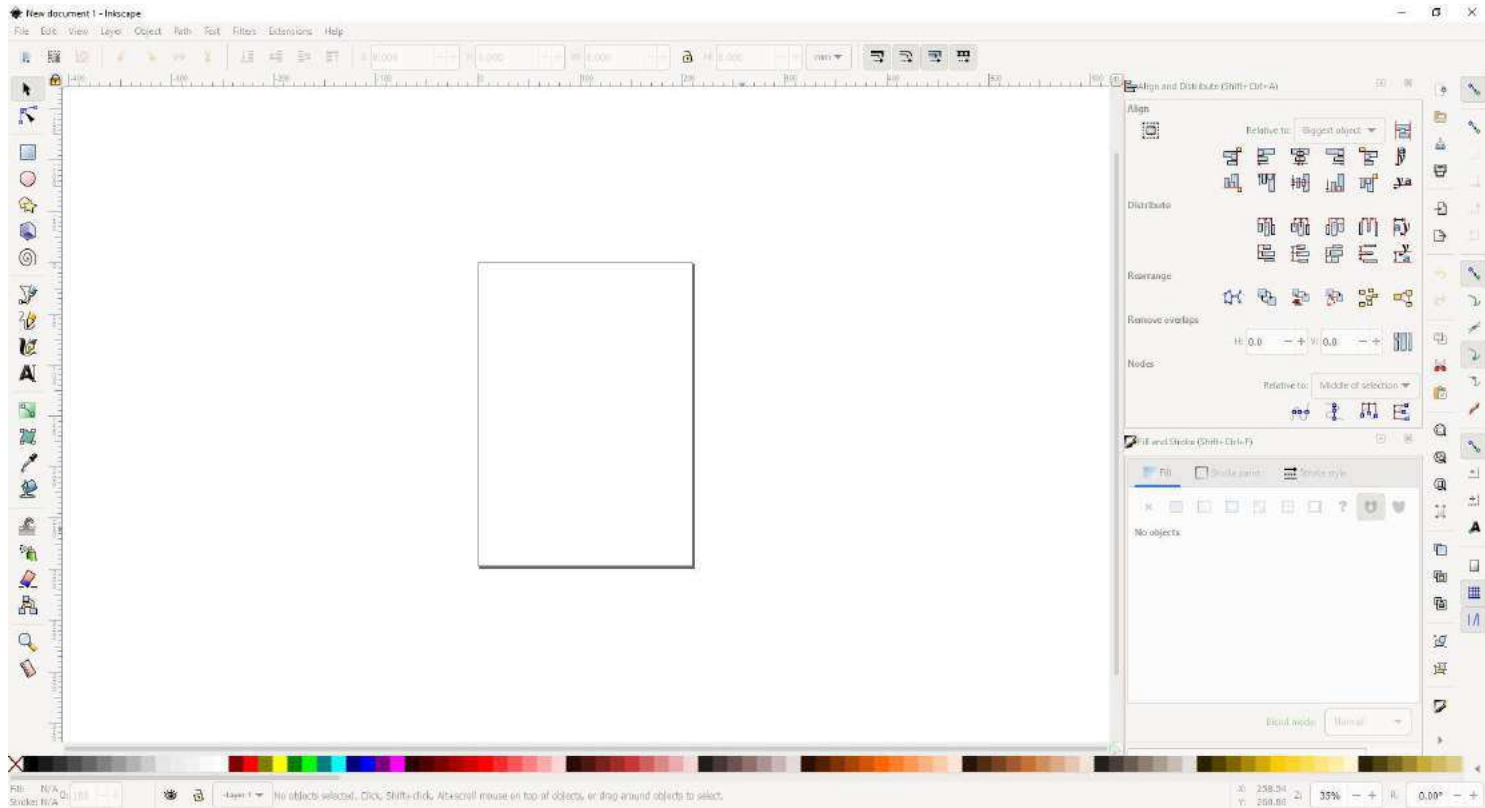



Inkscape tutorial: 2-Create-square

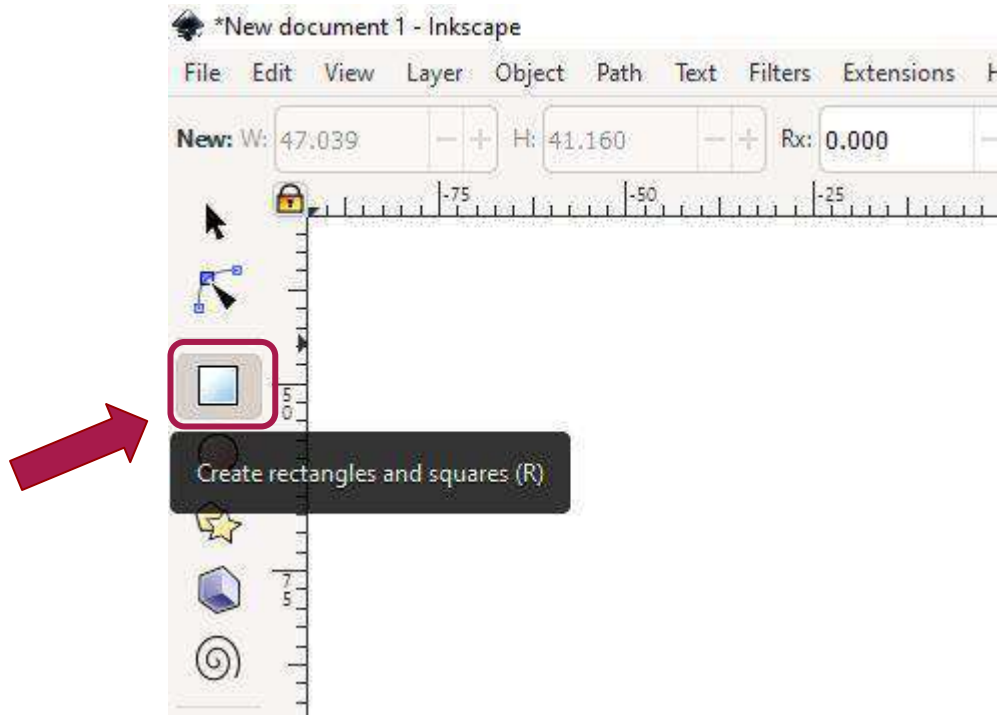



Inkscape tutorial: 3-Size-square

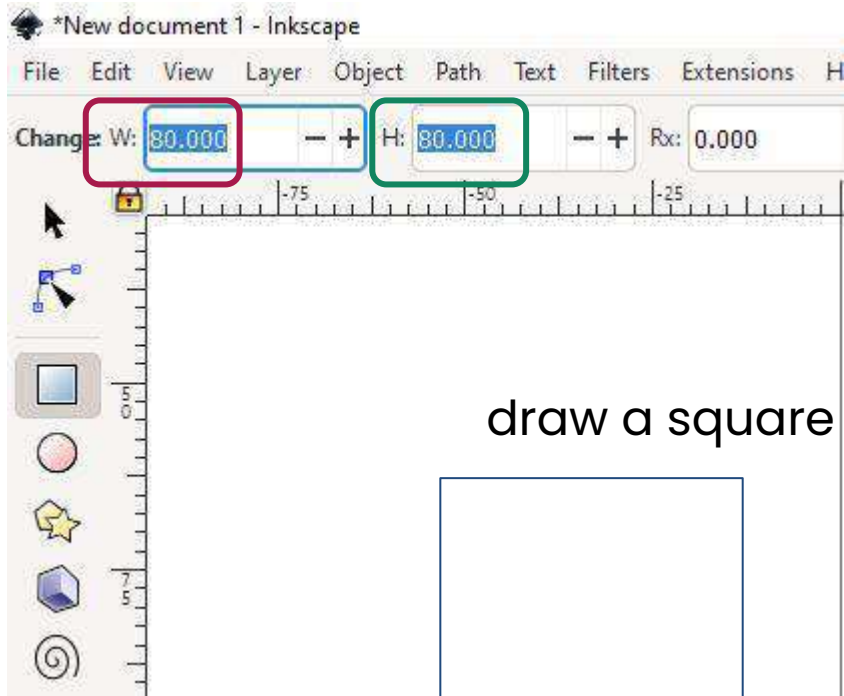

draw a square **80mm Width** and **80 mm Height**



Inkscape tutorial: 4-Object-Transform-Rotate

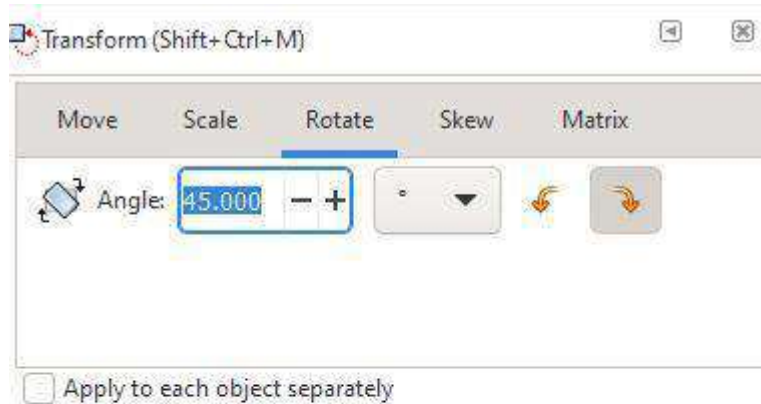

Object > Transform > Rotate





Inkscape tutorial: 4-Before-Rotate-Add-square-color

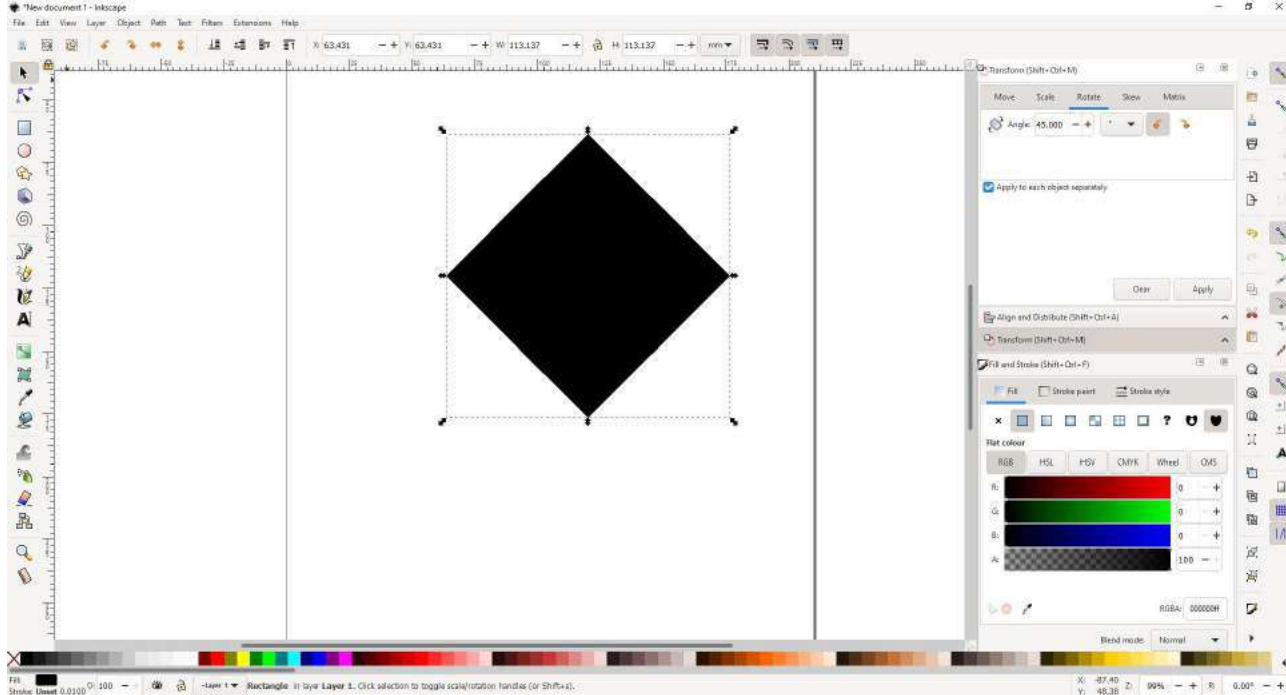

Object > Fill and stroke
Fill: No fill



Inkscape tutorial: 4-Before-Rotate-Add-square-stroke

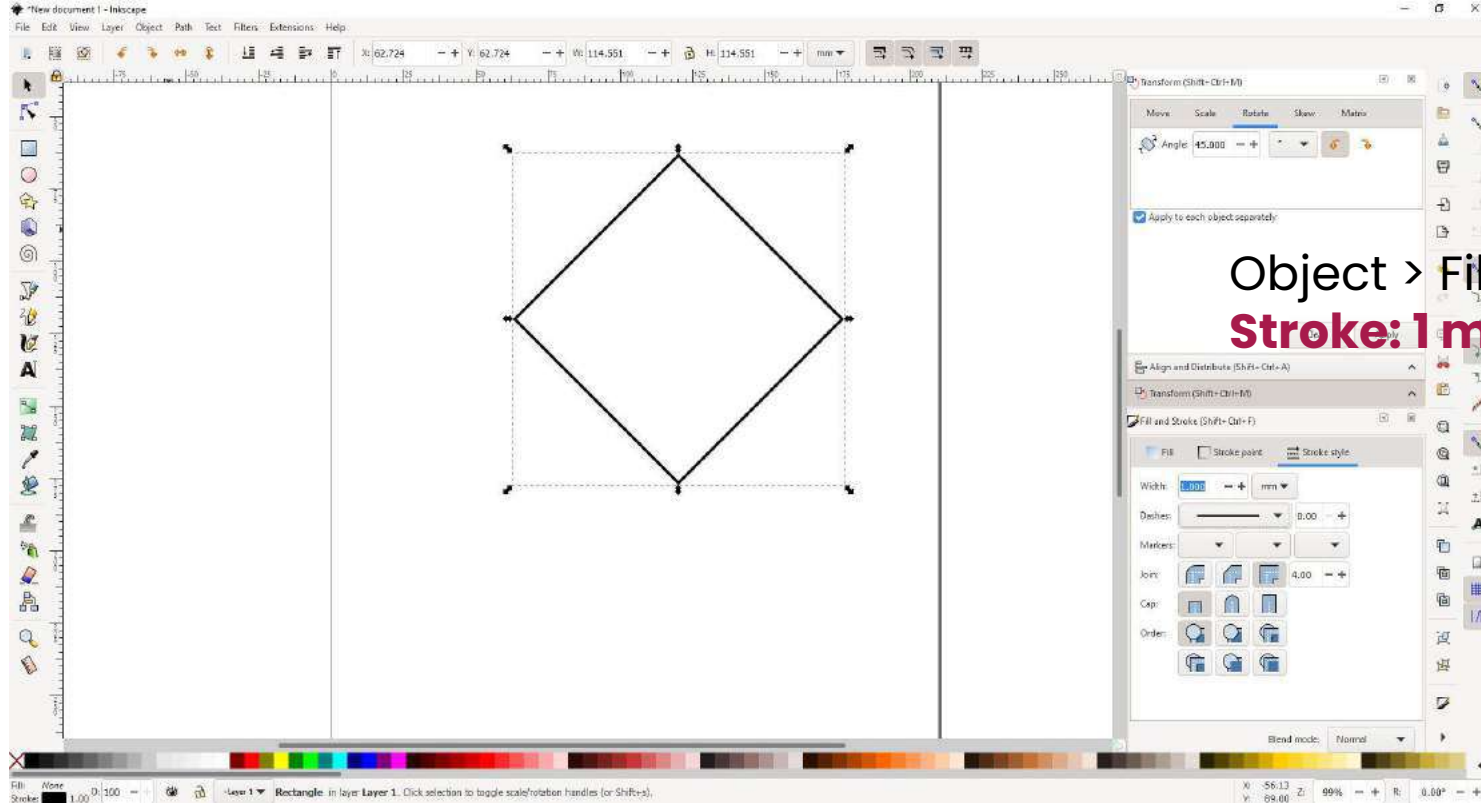

Object > Fill and stroke
Stroke: 1 mm



Inkscape tutorial: Create a 2nd square inside (middle point)

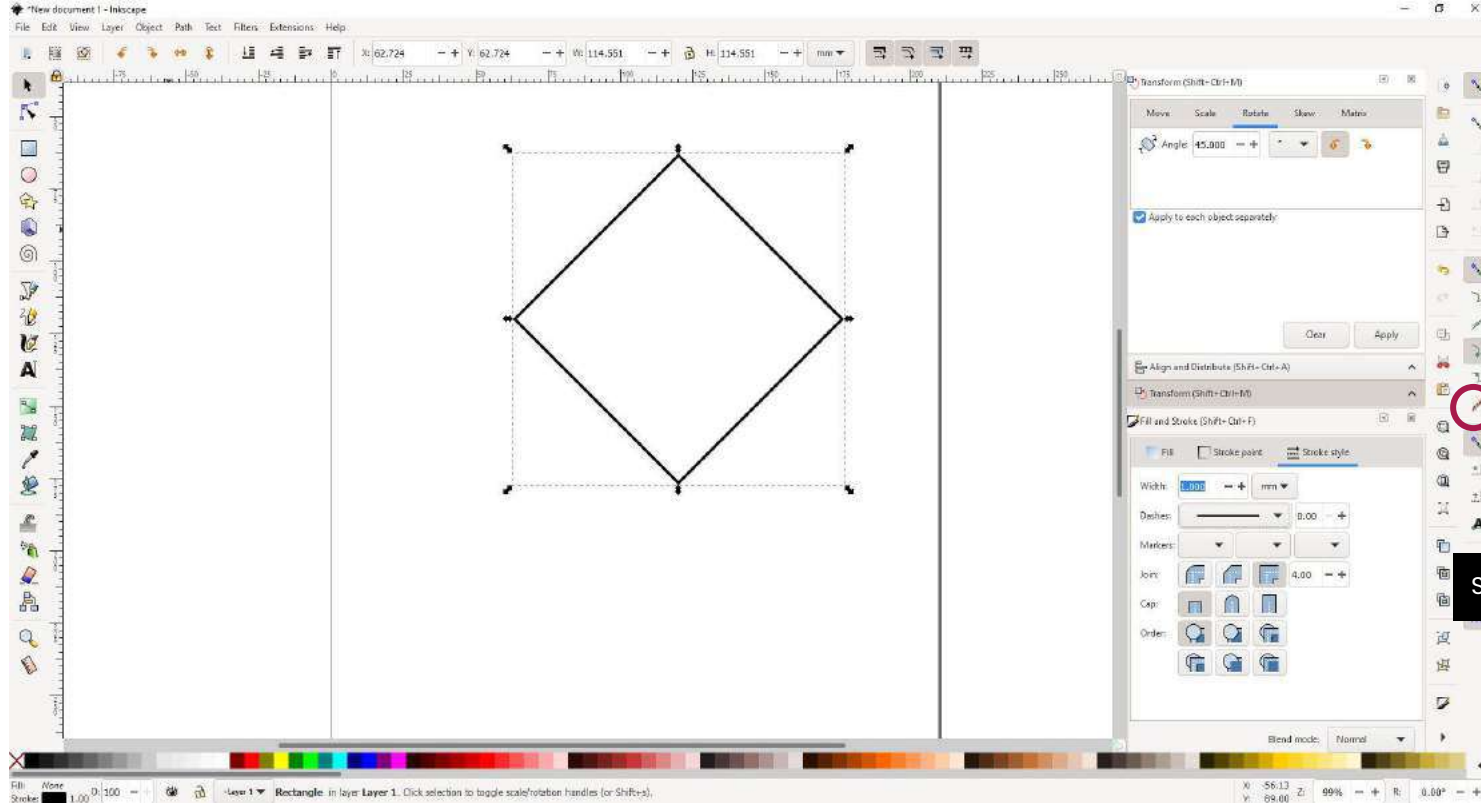

Snap midpoints of line segments



Inkscape tutorial: Create a 2nd square inside (middle point)



Snap midpoints of line segments

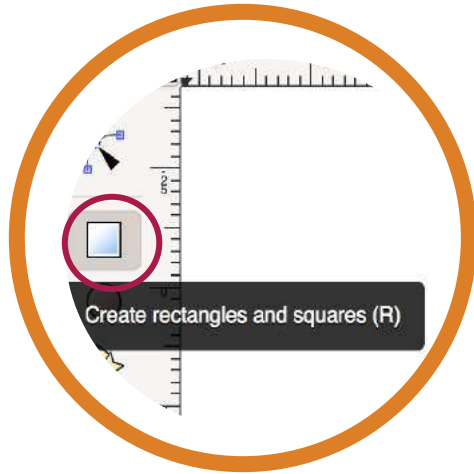

1-Draw a square with the snap midpoints selected

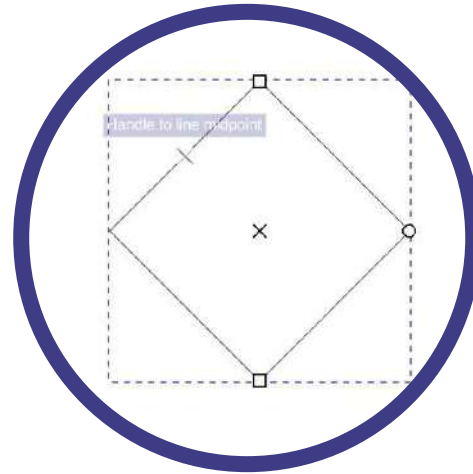

2-First corner of the square in the middle of on of the square lines

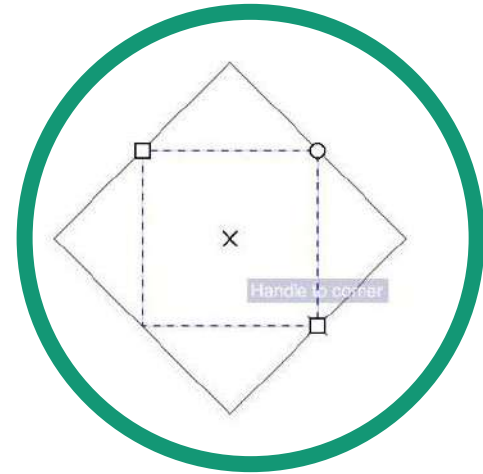

3-Drag the square to the midpoint of the opposite square line.



Inkscape tutorial: 5-Create-2nd-square-inside

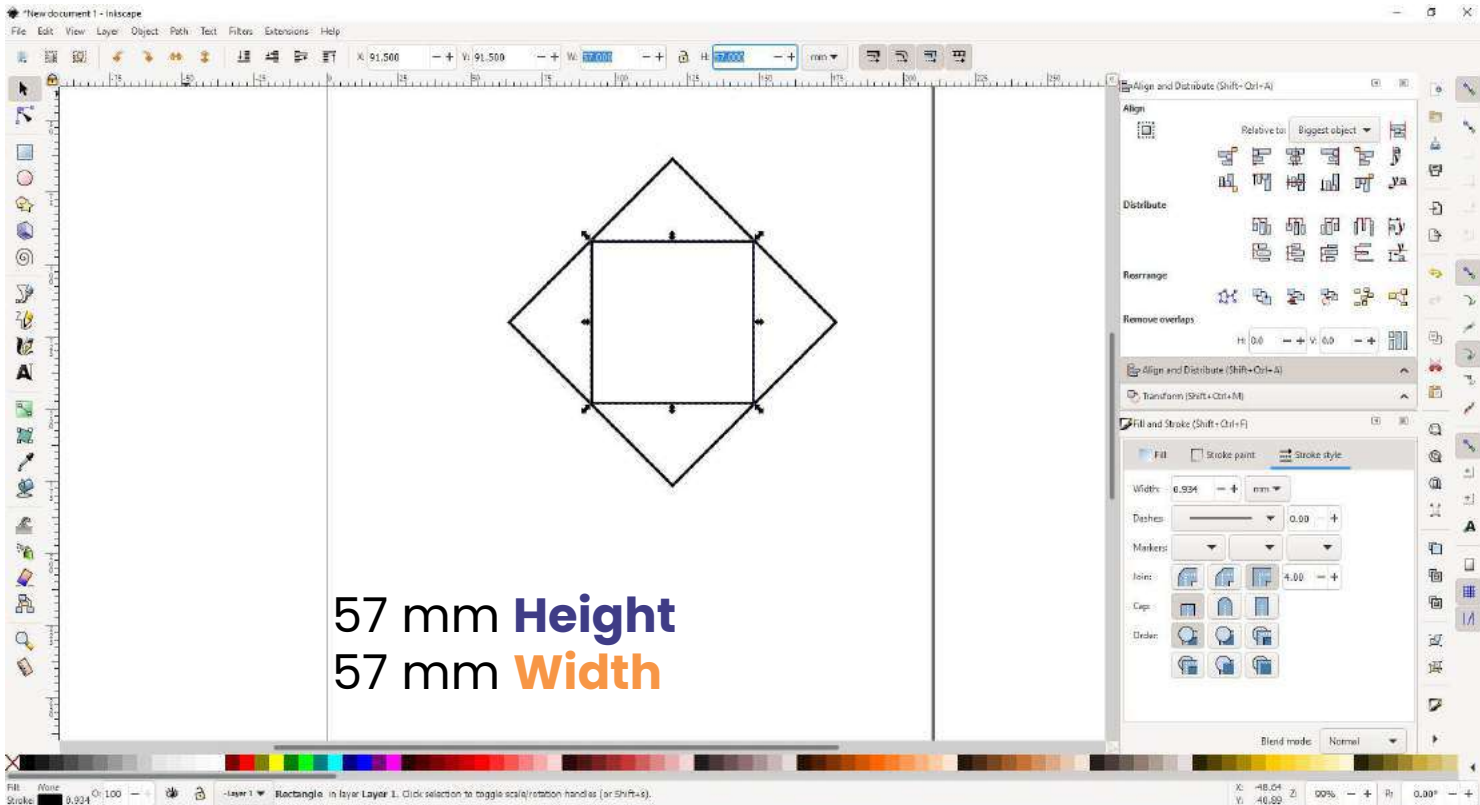



Inkscape tutorial:

6-Create-rectangle-half2nd-squaresize-x-materialthic kness

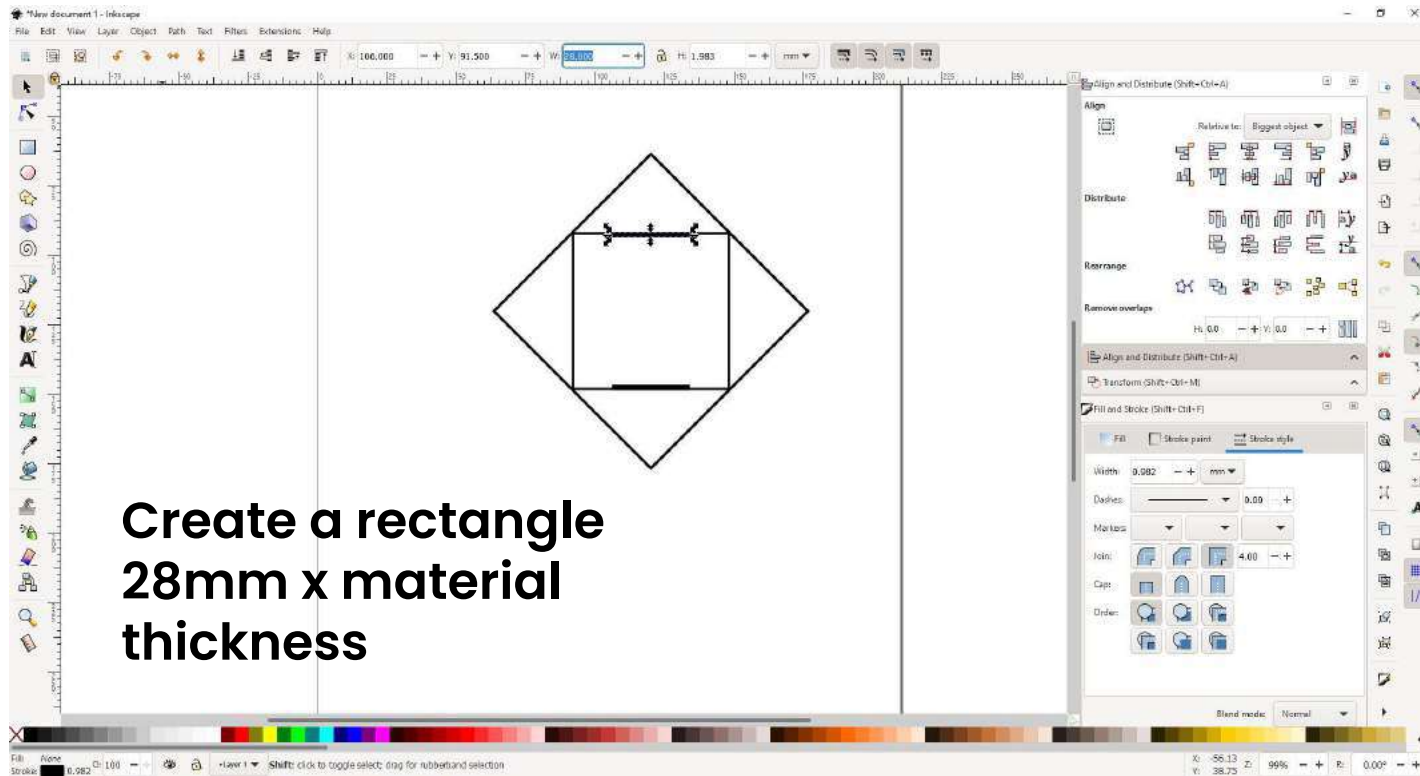



Inkscape tutorial: 7-Copy-and-center-on-each-side

copy and center on each side



Inkscape tutorial: 8-Create-rectangle-externalpart

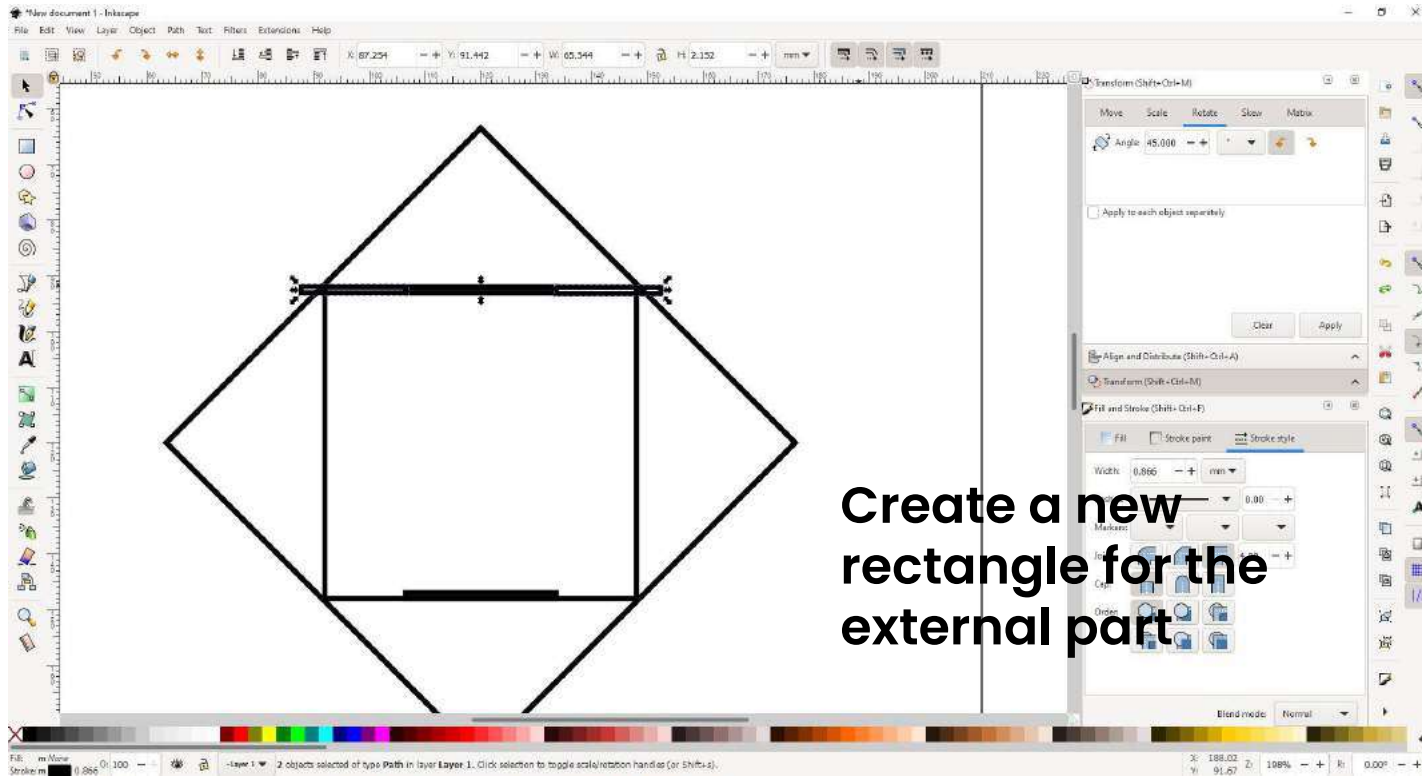



Inkscape tutorial: 9-duplicate-Create-rectangle-externalpart

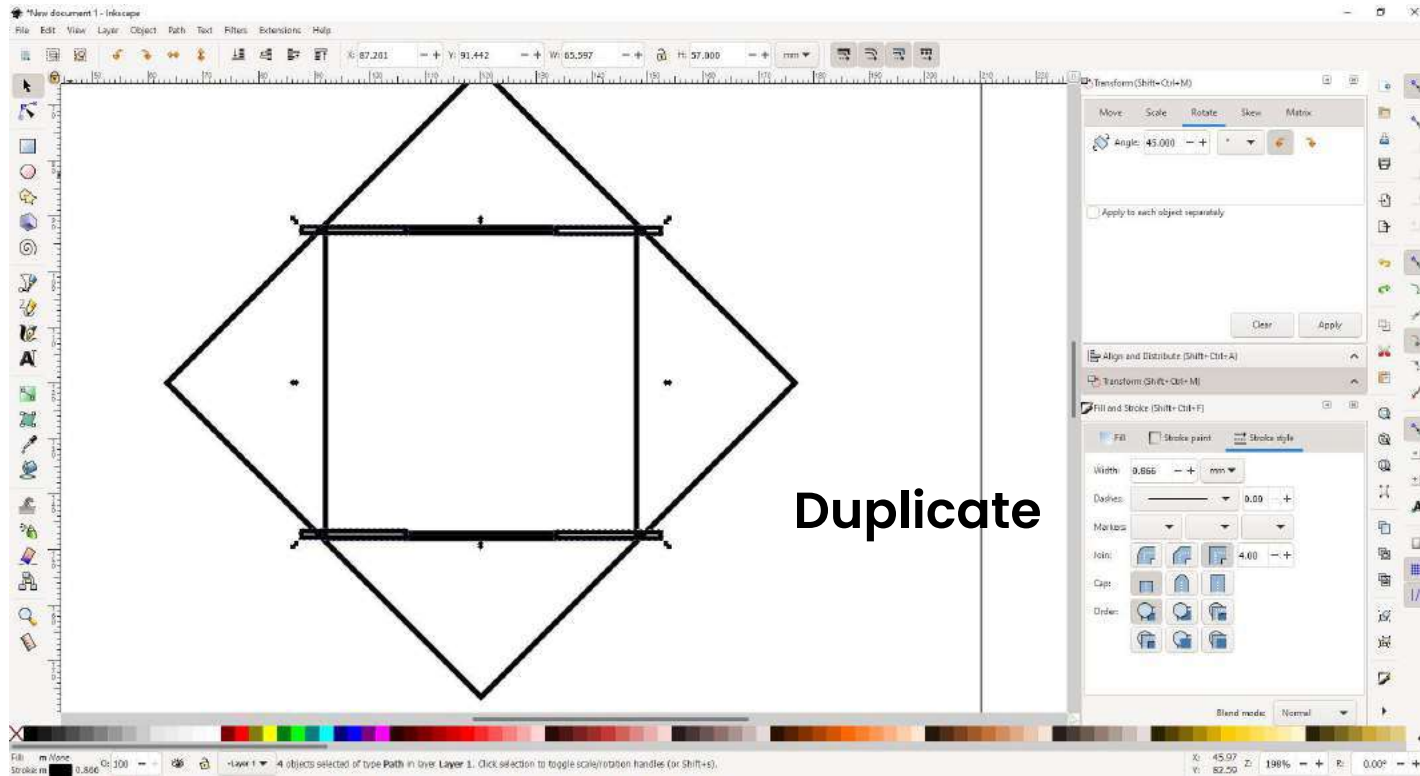



Inkscape tutorial: 10-rotate-internal-square-90deg

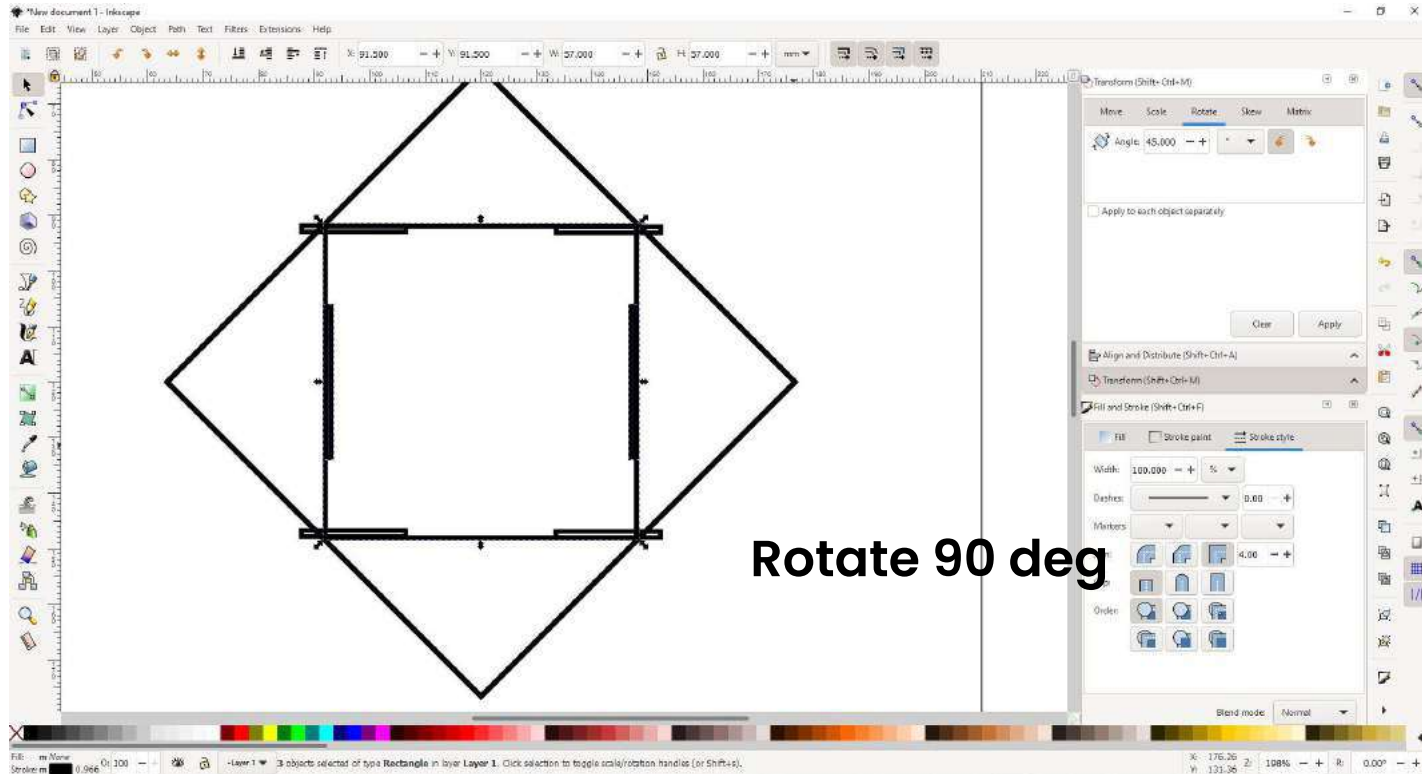



Inkscape tutorial: 11-suppr-internalsquare

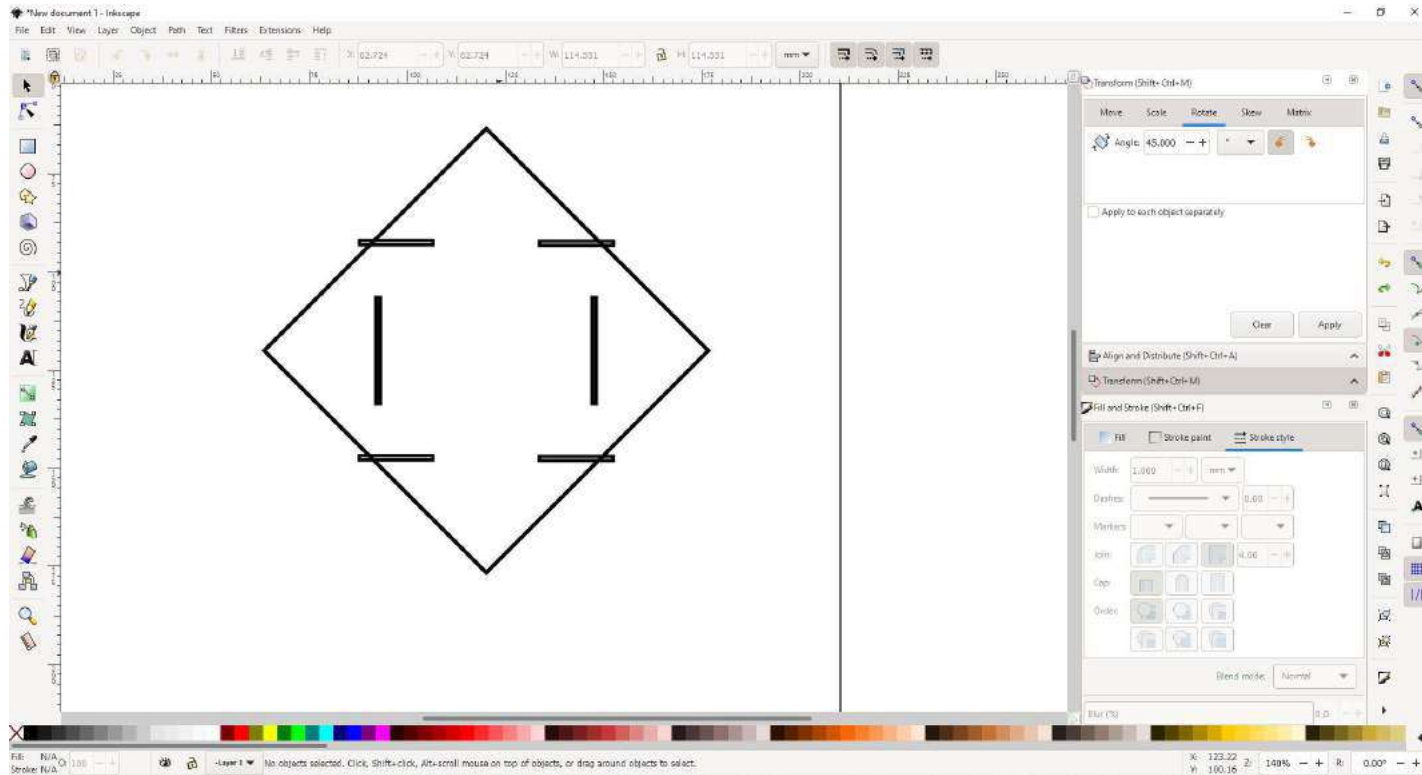



Inkscape tutorial: 12-path-difference-

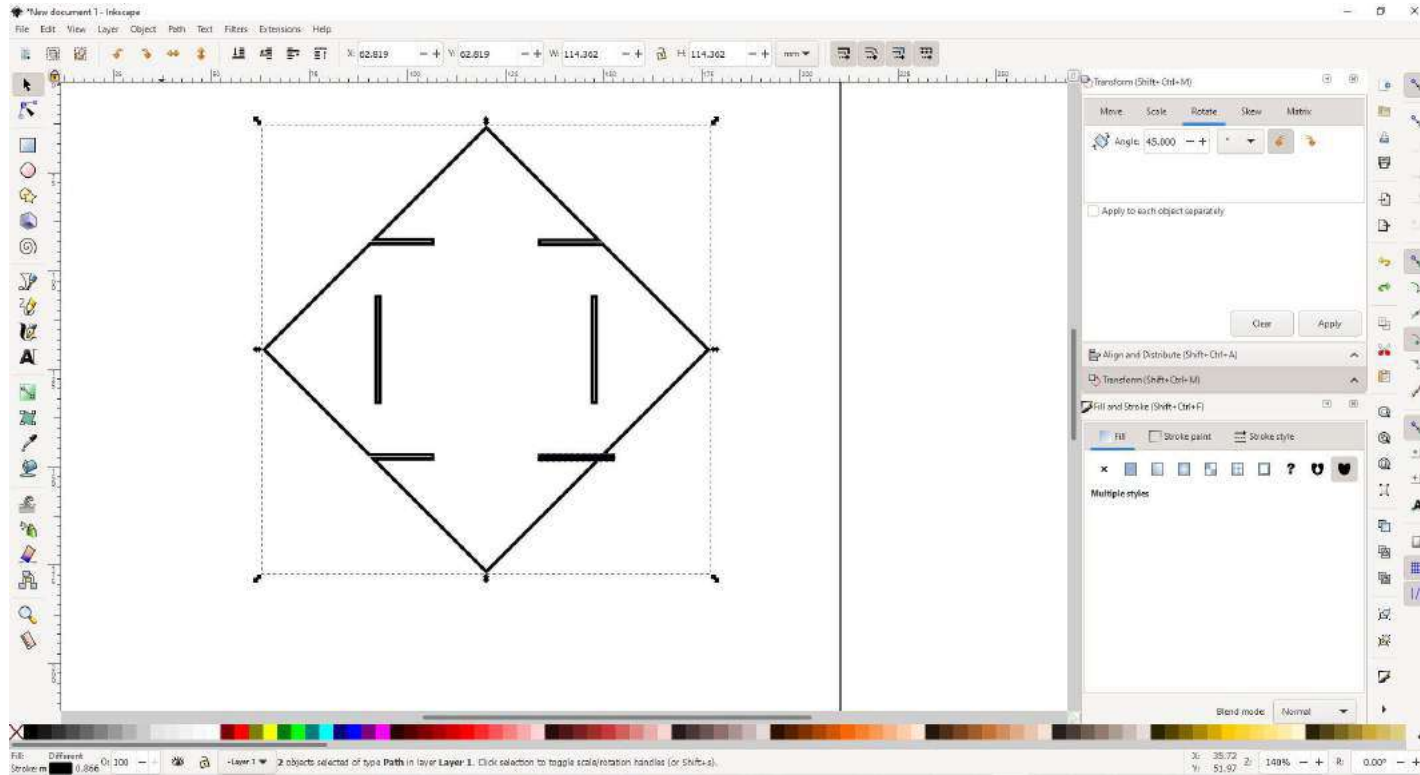



Inkscape tutorial: 13-select-all-strokesize-forlaser-cut

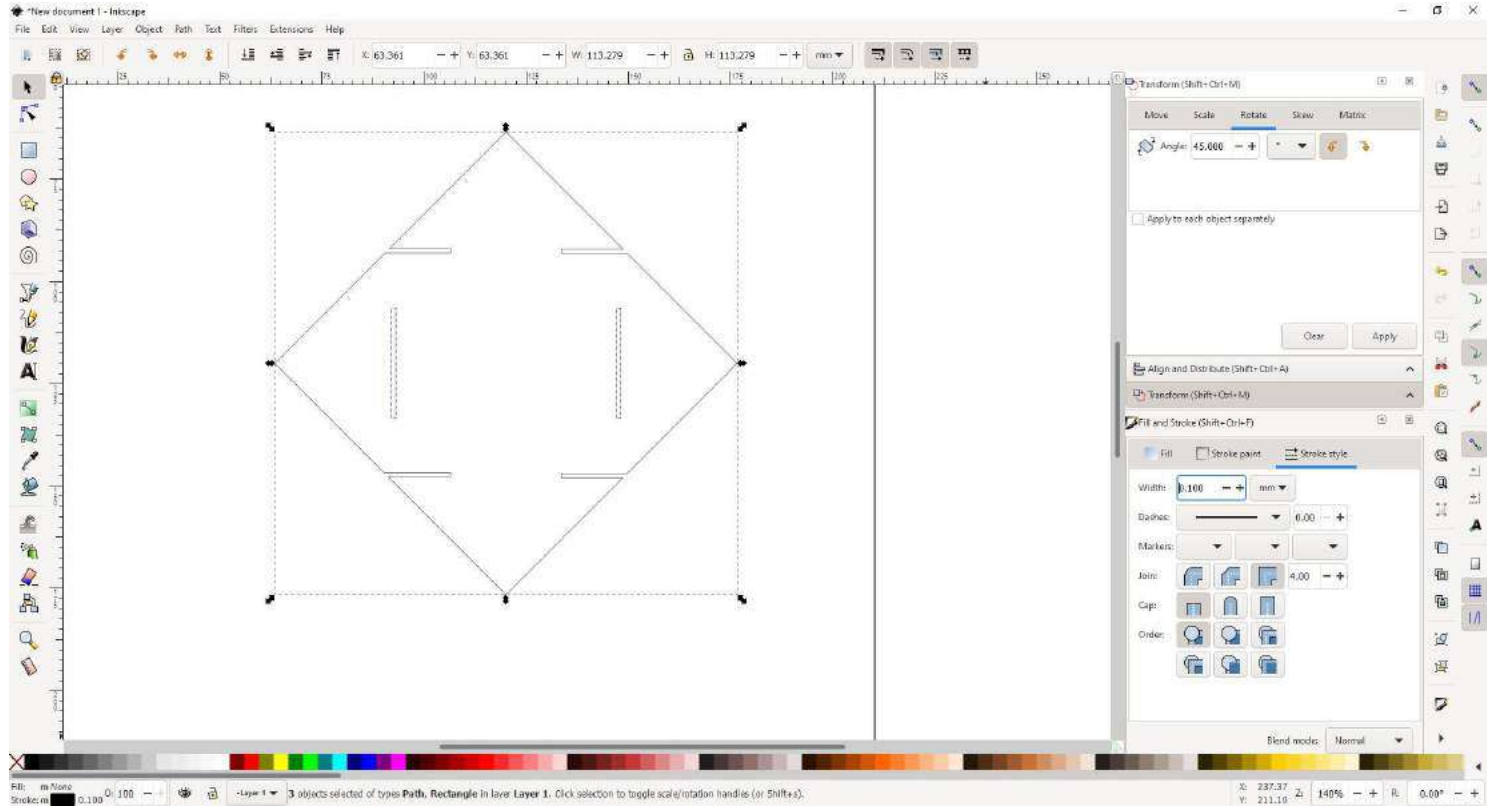



Inkscape tutorial: save as PDF to cut in the lasercutter

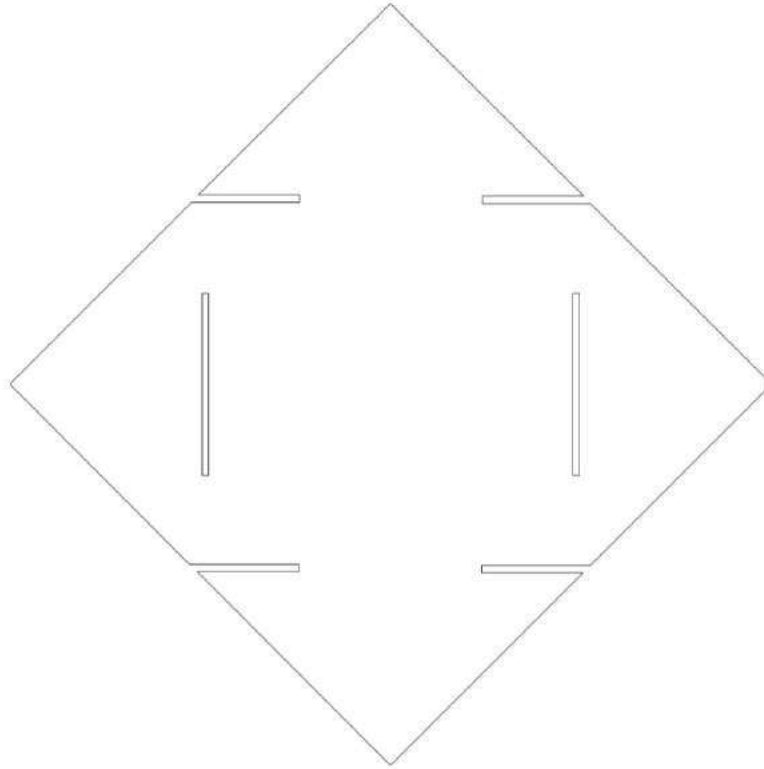



LaserCut and Interlock the modules





Next step

Challenge :

**Try to design the Takehiro
Ando Cuma piece**

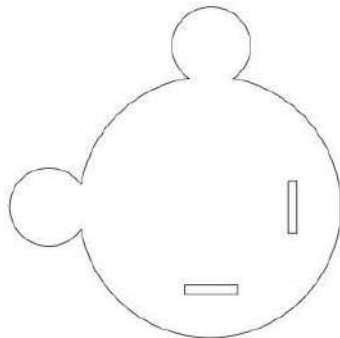



Next step

Share your creations :

**We love to see different models,
please , share yours in IG and tag
@shemakes_eu @fabricademy
@fablableon and @you**



Next step

Challenge 2:

Make a garment



Design the garment

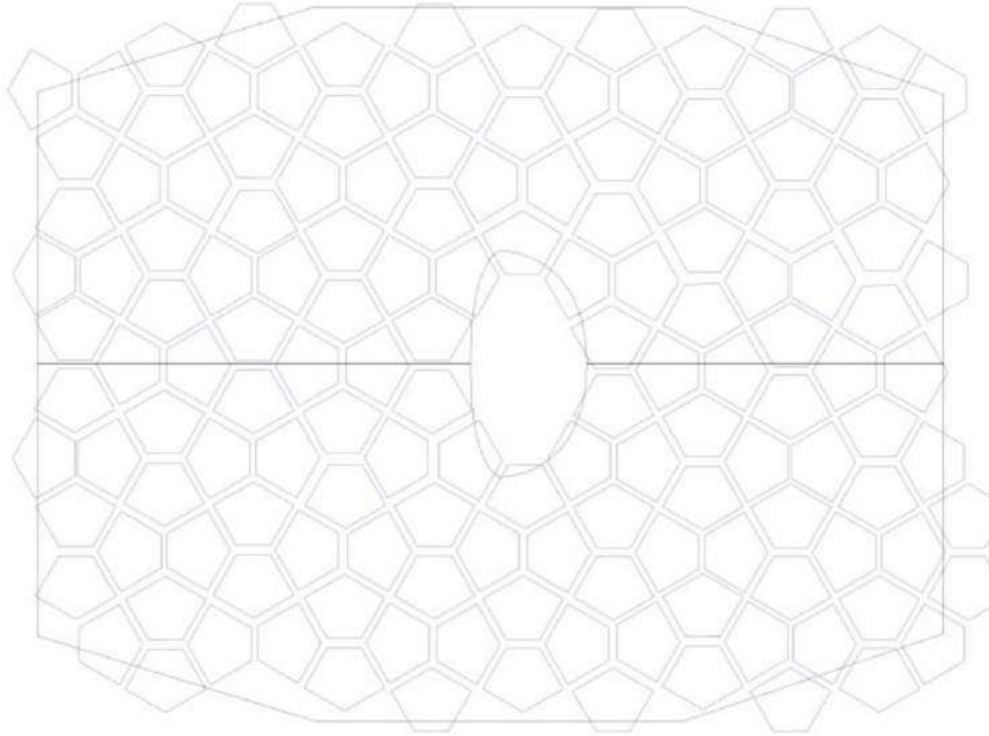

- Design a module in inkscape with the interlockings
- Use one of the flat sewing patterns to have an idea of the number of pieces you need



Design the garment

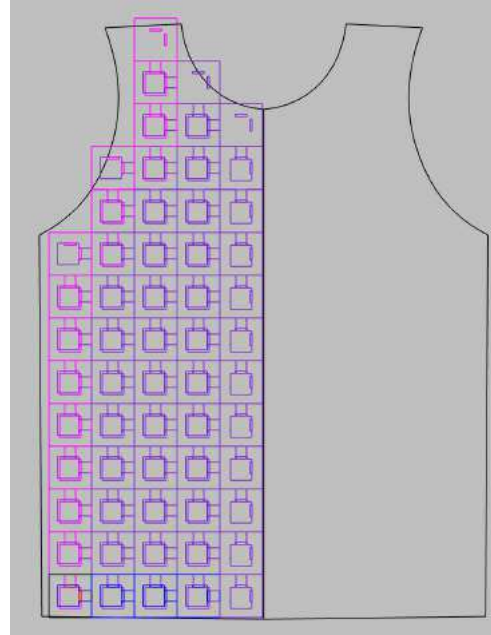
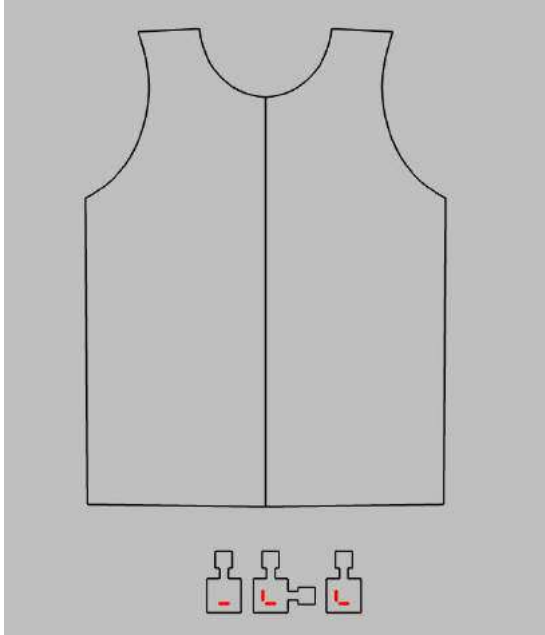

Design a module in inkscape with the needed interlockings to connect all the modules

Use one of the flat sewing patterns to have an idea of the number of pieces you need



Cut and assemble



Cut the modules
on the laser cutter
and assemble the
garment



Examples

Galya Rosenfeld



Zoe Romano | Fabricademy



Examples

Mary Ann Williams

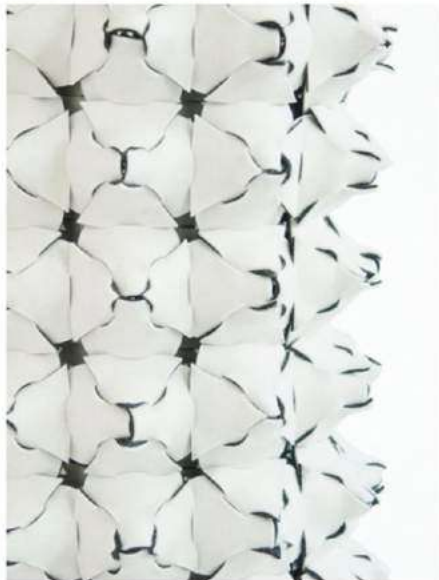

Zoe Romano | Fabricademy



Visit oscircularfashion.com to get inspired

oscircularfashion.com



05/11/2018
by Fanni Huszár 1 12



02/11/2018
by Fanni Huszár 0 14



03/05/2018
by Wei Cheung 0 3



01/05/2018
by Sofia Gundi 0 2



24/10/2018
by Dotun Ajewole 0 15

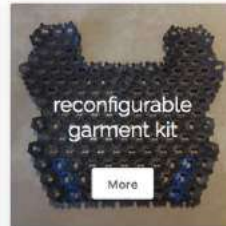

reconfigurable garment kit
More
23/10/2018
by Romain Di Vozzo 1 10



23/10/2018
by Chiara Garzerla 0 0



21/10/2018
by teresa van twuijver 1 10



26/04/2018
by esin durmaz 0 4



19/04/2018
by Luis Dulanto 0 12

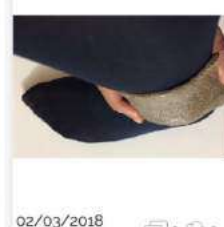

02/03/2018 0 6



02/03/2018 0 6

shemakes

Thank you

www.shemakes.eu



This project has received funding from the European Union's Horizon 2020 research and innovation programme under grant agreement No 101006203.